

## **H-1741-1 Fencing**

**(Rel 1-1572, 12-6-89)**

**Note: To return to the Range Handbooks Index, please click [Here](#)**

H-1741-1 - FENCING

Table of Contents

<u>Chapters</u>	<u>Page</u>
Introduction and Purpose . . . . .	i
I - Identifying the Need for Fencing. . . . .	I-1
II - Coordination Standards. . . . .	II-1
A. Planning and Environmental Analysis . . . . .	II-1
B. Internal BLM Coordination and Interdisciplinary Review. . . . .	II-1
1. Energy and Mineral Development. . . . .	II-1
2. Public Land Disposal. . . . .	II-2
3. Recreation. . . . .	II-2
4. Visual Resources. . . . .	II-2
a. Location. . . . .	II-2
b. Alignment . . . . .	II-2
c. Construction Practices. . . . .	II-2
5. Wild Horse and Burro Habitat. . . . .	II-3
6. Safety. . . . .	II-3
7. Soils and Water . . . . .	II-3
8. Grazing Management. . . . .	II-3
9. Wildlife. . . . .	II-4
C. Statutory Requirements for Coordination . . . . .	II-4
1. Threatened or Endangered Plants and Animals . . . . .	II-4
2. Cultural Resources. . . . .	II-4
3. Wilderness Study Areas (WSA) and Designated Wilderness. . . . .	II-4
D. External Coordination . . . . .	II-5
1. Livestock Operators . . . . .	II-5
2. District Grazing Advisory Boards. . . . .	II-5
3. Conservation Organizations. . . . .	II-5
4. Federal, State, and Local Government Agencies . . . . .	II-5
5. State and Local Highway Departments . . . . .	II-5
6. Authorized Public Land Users. . . . .	II-6
7. Public Access . . . . .	II-6
8. Fences Along Public - Private and Public - State Land Boundaries . . . . .	II-7-8
III - Investment Analysis Standards . . . . .	III-1
IV - Fence Design/Construction Standards . . . . .	IV-1
A. Gates and Cattleguards . . . . .	IV-1
1. Wire Gates. . . . .	IV-1
2. Pole Gates. . . . .	IV-1
3. Board Gates . . . . .	IV-1
4. Metal Gates . . . . .	IV-1
5. Cattleguards. . . . .	IV-2
6. Stiles and Fence Ladders. . . . .	IV-2
B. Public Lands Identification . . . . .	IV-2

## H-1741-1 - FENCING

<u>Chapters</u>	<u>Page</u>
C. Grounding Wire Fences . . . . .	IV-2
D. Standards for Big Game Habitat. . . . .	IV-3
1. Pronghorn Antelope and Javelina Habitat . . . . .	IV-3
a. Limitations . . . . .	IV-4
b. Standards for Pronghorn Antelope. . . . .	IV-5
c. Areas of Seasonal Pronghorn Antelope Movement . . . . .	IV-5
d. Standards for Javelina. . . . .	IV-5
2. Deer, Elk, or Moose Habitat . . . . .	IV-5
a. Limitations . . . . .	IV-5
b. Standards . . . . .	IV-6
c. Deer, Elk, or Moose Seasonal Migration Areas . . . . .	IV-6
3. Bighorn Sheep Ranges. . . . .	IV-7
a. Desert Bighorn Sheep Ranges . . . . .	IV-7
1. Limitations . . . . .	IV-7
2. Standards . . . . .	IV-8
b. Other Bighorn Sheep Ranges. . . . .	IV-8
E. Standards for Wild Horses and Burros . . . . .	IV-8
1. Cattleguards. . . . .	IV-8
2. Gates . . . . .	IV-8
3. Fences. . . . .	IV-9
F. Standards for Recreation Sites . . . . .	IV-9
1. Buck-and-Pole Fences. . . . .	IV-9
2. Post-Pole and Post-with-Pole-and-Wire Fences. . . . .	IV-9
G. Bison Range Fencing . . . . .	IV-10
H. Domestic Livestock Fences . . . . .	IV-10
I. Riparian Area Fencing . . . . .	IV-11
J. Nontraditional and Other Types of Fences . . . . .	IV-12
1. Suspension Fences . . . . .	IV-12
2. Electric Fences . . . . .	IV-12
a. Short-Time Holding. . . . .	IV-12
b. Design for Cattle . . . . .	IV-12
c. Smaller Livestock or Mixed Groups . . . . .	IV-12
3. Smooth-Wire Fences. . . . .	IV-13
a. Applications. . . . .	IV-13
b. High-Tensile Wire . . . . .	IV-13
4. Adjustable Fences . . . . .	IV-13
5. Let-Down Fences . . . . .	IV-14
6. Study Enclosures and Enclosures . . . . .	IV-14
a. Enclosures. . . . .	IV-14
b. Enclosures. . . . .	IV-14
7. Deer- and Elk-Proof Fences. . . . .	IV-14
8. Fence Drainage Crossings. . . . .	IV-15
9. Other Special Management Situations . . . . .	IV-15
K. Preservative Treated Posts. . . . .	IV-15

## H-1741-1 - FENCING

<u>Chapters</u>	<u>Page</u>
V - <u>Modification and Removal of Existing Fence.</u> . . . . .	V-1
A. <u>Criteria</u> . . . . .	V-1
B. <u>Responsibility for Modification</u> . . . . .	V-1
C. <u>Responsibility for Removal</u> . . . . .	V-2
VI - <u>Maintenance</u> . . . . .	VI-1
VII - <u>Reconstruction.</u> . . . . .	VII-1

Glossary of TermsIllustrations

1. BLM Fence Standards for Livestock and Wildlife
2. BLM Wire Spacing Standards
3. Typical Wire-Mechanical Gate Closers and Examples of Stiles and Walk-Through Passes
4. Barrier Height Increase of 42" Fence on Contour of Different Percent Slopes
5. Typical Antelope Pass
6. Examples of Adjustable Three-Strand 38" High Fence for Antelope
7. Examples of Adjustable Four-Strand Fence for Deer
8. Examples of Fastening Mechanisms for Adjustable Wire Fence
9. Example of a Let-Down Fence
10. Fence Stays
11. Typical Post & Pole, Buck and Pole and Post, Pole, and Wire Fences
12. Examples of Smooth-Wire and Barbed Wire Suspension Fences
13. Examples of Electric Fences
14. Examples of Strain Insulator for Adjustable Wire Fences
15. Study Exclosure
16. Examples of Big Game Proof Fencing and the Oregon Outrigger Fence
17. Examples of Bison Fencing
18. Examples of Rock Crib Fencing

## H-1741-1 - FENCING

Preface

Introduction and Purpose. This Handbook supplements the general renewable resource improvement and treatment guidelines and standards described in Manual Section 1740 and Handbook H-1740-1. It identifies standards and provides guidance related specifically to construction of fences on lands managed by the BLM.

Engineering guidance, specifically that related to facility planning and design is contained in Manual Sections 9101 and 9102. Adequate planning, coordination, and identification of multiple use resource management objectives for the management unit or site where a proposed fencing project would be installed are essential for the application of this guidance. Use of the project planning procedure and a checklist, as described in Chapter 2 of H-1740-1, will usually assure that all relevant factors are incorporated in the final design and installation of a fence, if one is constructed.

## H-1741-1 - FENCING

## Chapter 1

Chapter 1 - Identifying the Need for Fencing.

Fencing is one of several means of controlling animals to achieve resource management objectives. Fencing is commonly used on range and forest lands to control domestic livestock, to exclude certain livestock and wildlife species from hazard and study areas, to protect seedings, and to protect other human and cultural values. Other animal control techniques include herding, use of natural landforms to limit movement, designation of dual-use areas, exclusion of certain kinds and types of livestock, selective placement, and use of salt and water sources, etc. A growing awareness of the benefits that may be realized from the day-to-day supervision and management of livestock, as well as a need to keep fence installation and maintenance costs low, have rekindled interest in herding.

Although the effectiveness of each alternative must be evaluated within the context of site conditions and management objectives, all means of animal control should be considered before deciding to use a specific technique. The cost and potential effects of fencing require that its use be considered carefully. Selection of the appropriate type of fence can mitigate or avoid many potentially adverse impacts and provide the desired level of animal control. Consideration of all affected resource values is necessary before deciding to use this sometimes controversial management practice. New materials, designs, construction practices, and a need to obtain better utilization of the vegetation resource have all contributed to a wider acceptance of fencing. New types of electric and suspension fencing are two examples.

In summary, careful analysis of management objectives, potential adverse and beneficial effects, costs, and consideration of the alternative types and designs available will lead to design of a fence for a specific site that accomplishes desired objectives and avoids undesired impacts and controversy. The design standards described in this Handbook encompass a variety of resource management situations. Thus, some flexibility exists to match fence design with multiple use objectives in most situations. Since this Handbook does not describe every fence design found to be satisfactory in certain situations, managers may authorize the use of other fencing if an interdisciplinary analysis of resource management objectives (including the need to provide for the movement of wildlife), current and potential use conflicts, and coordination with affected interests indicate that a need exists and that potentially adverse impacts can be avoided or mitigated. The rationale for departures from the standards described in this Handbook must be documented, however.

## H-1741-1 - FENCING

## Chapter 2

Chapter 2 - Coordination Standards

A. Planning and Environmental Analyses. Decisions to use or to exclude a particular type or all fencing within a specific geographic area should always evolve from the interdisciplinary consideration of resource values, public needs, and issues identified during the land use planning or resource management plan/environmental impact statement (RMP/EIS) process. Resource management (program) objectives must be defined before a means of achieving them is selected. Site-specific improvements should be identified and receive the appropriate environmental and other analyses during activity planning. The BLM use of the proposals and environmental analyses of cooperating agencies having special expertise on fencing issues are recommended (40 CFR 1501.6).

B. Internal BLM Coordination and Interdisciplinary Review. Proposed fencing projects must be coordinated among affected resource programs to assure that all resource values and needs are considered. The most efficient means of accomplishing this is to identify and analyze proposed fencing in the land use planning and/or activity planning processes. The project planning and documentation steps encompassed in the project planning checklist (see H-1740-1, Chapter 2) provide a means of assuring that proposed fencing projects receive the appropriate interdisciplinary review and coordination. The basis for fencing project approval and rationale for selection of a particular type of fence should be readily apparent in resource clearances and/or analyses of environmental, technical, and economic feasibility contained in a project file. BLM resource program concerns include the following:

1. Energy and Mineral Development. Proposed fences should not be constructed in energy and mineral development areas unless:

a. The fence will not be affected by that development, or is a required part of the development.

b. The principal features or components of the fence can economically be salvaged and used again.

c. The benefits yielded, before the fence is destroyed or abandoned, will exceed the cost of installing and maintaining the fence.

When minerals development is expected or when a short-term need for fencing exists (i.e., during land rehabilitation), electric fencing may provide an easily removable and cost-effective means of animal control.

## H-1741-1 - FENCING

## Chapter 2

2. Public Land Disposal. Proposed fences should not be constructed on areas identified for sale or exchange to another entity unless one or more of the conditions above is met or the value of fence is reflected in the value of the lands being sold or exchanged.

3. Recreation. Fencing can restrict access to developed or undeveloped recreation use areas. Thus, fence construction must be consistent with recreation area management plans, off-road vehicle designations or closures, and other recreation related land use planning decisions.

4. Visual Resources. Where decisions have been made as a result of land use planning, environmental impact assessment, or activity planning to mitigate the visual impacts of fencing, use the following guidelines:

a. Location. When consistent with the need for fencing, place fences along natural changes in vegetation type and parallel to natural features and topographic relief. Avoid fences centered on the crest of a hill or ridge-line. Place the fence along the edge of small valleys or clearings rather than in the middle. When crossing roads, use natural features or vegetation as screening to reduce visual awareness. Also avoid locating fencing on slopes where wildlife movement would be a problem. (See Illustration 5.)

b. Alignment. Where practical, use straight sections of fence when approaching or crossing roads. The fence should be straight on each side of a cattleguard for at least 60 feet. Bends or curves in a fence line should be designed such that drifting livestock or wildlife are not diverted onto a cattleguard or into corners where they tend to collect and mill around along the fence. However, changes in alignment can reduce or eliminate visual impacts.

c. Construction Practices. Avoid bulldozer clearing or other major soil disturbing methods. In brushy areas, keep the cleared area to the minimum needed to allow construction. In critical scenic areas, use only hand clearing. In areas with heavy vegetation, consider irregularly shaped fence line clearings rather than those with uniform width. Mechanical clearing can be quite successful if accompanied by rehabilitation actions that minimize soil loss and avoid long-term contrasts in vegetative cover. Use the most practicable, unobtrusive materials.



## H-1741-1 - FENCING

## Chapter 2

5. Wild Horse or Burro Habitat. Fencing can adversely impact the wild free-roaming behavior which characterizes wild horse and burro herds. Compatible types of fences for wild horse and burro management include drift fences, study and exclosure area fences, temporary fences used in gathering horses, and perimeter fences around herd areas. Within herd areas, let-down and adjustable fences should be used only when they are designed to avoid injuring animals that move through the opening. Double gates are the preferred means of providing for wild horse and burro movement within herd areas. (Two standard wire gates both of which attach to a post or panel in the center of the double-wide opening.) Other animal control measures should also be considered during the planning process.

6. Safety. BLM employees have a responsibility to assure that safety guidelines are followed during fence construction and maintenance. (See Manual Section 1112 and Handbook H-1112-1.) Flagging should be used whenever there is a need to alert either humans or animals to the existence of a fence. Wire fences should be grounded to provide protection from lightning.

7. Soils and Water. Soils information is needed for the proper location and design of fencing. For example, an area with sandy soil will require more braces and closer spacing of posts than an area with firm soils. Rocky soils may require that rock cribs be used instead of posts and for brace panels. The presence of water, either permanently or seasonally, may require the use of flotation boards and other devices, including special braces. Breakaway fences, swinging panels, and floating water gaps may be needed to span running or seasonal stream channels.

8. Grazing Management. Fences must be designed and constructed in a manner that ensures adequate control of livestock consistent with achieving wildlife, recreation, vegetation management and other program or resource objectives. It is often assumed that proposals to use fencing originate in and are developed to achieve livestock grazing and/or rangeland management program objectives. Since fencing projects may be proposed by other program or resource interests, all proposed fencing projects should be reviewed by a BLM employee familiar with the livestock and vegetation management objectives for the area affected. Coordination with affected authorized users is also required (see Section D).

## H-1741-1 - FENCING

## Chapter 2

9. Wildlife. Fencing proposals should be reviewed by wildlife program personnel early in the planning process to assure that adverse impacts on wildlife are either avoided, mitigated, or are consistent with management direction. State wildlife agency input during the interdisciplinary or land use planning process is needed to identify seasonal movement patterns, migration routes, and concentration areas. The fence standards discussed in Chapter 4 and shown in the Illustrations include designs that provide adequate protection or mitigation for wildlife under most circumstances. The design standards discussed in Chapter 4 must be applied within the context of the conforming and conflicting resource use values existing on lands managed by the BLM and may apply to other fences which could enclose or block wildlife access to public lands (see Chapter 2.C.8.).

C. Statutory Requirements for Coordination. (See Manual Section 1740.11.)

1. Threatened or Endangered Plants and Animals. See Manual Section 6840 for guidance on consultation with the U.S. Fish and Wildlife Service, if a proposed fencing project may affect a federally listed species. The BLM policy on federally listed species, species proposed for listing, candidate species, sensitive species, and State listed species is contained in Manual Section 6840.06. Memoranda of agreement with State government agencies should identify procedural guidelines that apply within that State.

2. Cultural Resources. 36 CFR 800 sets forth procedures that shall be used when management direction or other data identifies that a cultural resource inventory may be needed.

3. Wilderness Study Areas (WSA) and Designated Wilderness. Manual Section 8550 and Handbook H-8550-1 (Interim Management Policy and Guidelines for Lands Under Wilderness Review) contain BLM policy and guidance for management of (1) lands for which the wilderness inventory process has not been completed and (2) WSA's. The general standard is that these lands be managed in a manner so as not to impair the suitability of such areas for preservation as wilderness. Handbook H-8550-1, Chapter II, discusses evaluation and notification procedures and recordkeeping requirements. "Guidelines For Specific Activities" are contained in Chapter III.

Manual Section 8560 and Handbook H-8560-1 (Management of Designated Wilderness Areas) provide guidance concerning Prohibition of Certain Uses (8560.12), Minimum and Acceptable Tools (8560.13), and the use and maintenance of livestock grazing management improvements and facilities (8560.15G). The general standard is that the wilderness character of the area be preserved and that livestock management improvements, existing at the time of designation and complying with an approved Allotment Management Plan (AMP), may continue in use. Rangeland management guidance is discussed in Manual Section 8560.37. There is also a requirement that Wilderness Management Plans be prepared for all wilderness areas on public lands. These plans guide the preparation or revision of other activity or action plans and contain detailed information concerning project design, maintenance, and reconstruction, including standards and stipulations for fencing projects.

## H-1741-1 - FENCING

## Chapter 2

D. External Coordination.

1. Livestock Operators. Permittees and lessees must be consulted and their cooperation sought during activity or project planning, concerning proposed fence construction, modification, or removal on the allotments they use. This coordination is necessary regardless of whether the objectives involve grazing management or other resource and program objectives. Except where fences are totally funded by the BLM, they must be authorized by either a Cooperative Agreement or Range Improvement Permit which identifies construction and maintenance standards and responsibilities, in addition to ownership of the fence.

2. District Grazing Advisory Boards. Where they exist, these boards must be consulted at least once annually and given an opportunity to offer advice and make recommendations concerning the development of AMP's and the utilization of range improvement funds for all approved types of improvement and treatment projects. This requirement is also applicable to coordinated activity plans that include the equivalent of an AMP.

3. Conservation Organizations. Coordination with conservation, environmental, and other interests which may be affected by fence construction, modification, reconstruction, or removal should occur as one part of public input during the planning process. Agreements reached during activity planning regarding participation in or responsibility for constructing, maintaining, or operating improvements (e.g., opening and closing gates, putting up or letting down let-down fences, etc.) should always be documented in a Cooperative Agreement.

4. Federal, State, and Local Government Agencies. Federal and State agencies such as the U.S. Forest Service, U.S. Fish and Wildlife Service, State land departments, and wildlife agencies will normally review fencing proposals during planning and environmental analyses. Annual coordination meetings with some State and local officials may be desirable.

5. State and Local Highway Departments. Coordination meetings between the BLM and State and/or local highway officials should be held, as needed, to assure that the needs and management responsibilities of each entity are reflected in the design of fences along roads and highways. BLM participation in Joint Memoranda of Understanding which include participation by State and local agencies and the Federal Highway Administration will generally facilitate coordination and consultation activities and provide a framework for discussion of specific fencing projects. The objectives of this coordination include ensuring that:

a. All multiple use values, including wildlife, wild horses and burros, domestic livestock, etc., are incorporated into the design of highways and highway fencing.

## H-1741-1 - FENCING

## Chapter 2

b. Areas where control of access to highways is needed are identified during the BLM planning process to the extent possible. The preferred means and/or general design of the most restrictive type of fencing should be identified in plan documents to facilitate the design of specific fences later.

c. Where restrictive fences are needed to control highway access, other means are provided for wildlife movement (e.g., underpasses, overpasses, etc.).

d. When unforeseen needs are identified following resource management plan completion, the project planning procedure described in H-1740-1 can be used to address site-specific needs and criteria in a timely manner.

e. The safety of the public is protected or enhanced and potential adverse effects on resource values are mitigated.

6. Authorized Public Land Users. Proposals to construct or modify fencing on public lands where specific use authorizations exist (rights-of-way, timber sales contracts, leases, etc.) must be coordinated with these land users. Adjustments in or modifications of proposed fencing, and the user's permit, lease, right-of-way, etc., may be necessary. The actions taken to achieve coordination, as well as the outcome, must be documented.

7. Public Access. Access to public lands, as identified in land use planning decisions, must be ensured.

## H-1741-1 - FENCING

## Chapter 2

8. Fences Along Public-Private and Public-State Land Boundaries. The responsibility to install fencing along the boundary between Federal public lands and lands owned by non-Federal entities (i.e., State, local, private) generally rests with the non-Federal landowners. The reason or basis for this is that the Federal Government is recognized as being "highest in rank and authority." The historical basis for this can be traced from English common law concerning the "rights of the sovereign." The modern basis is the Supremacy Clause of the United States Constitution. In fact, the existence and growth of the Federal public domain was a result of the establishment and legal recognition of national sovereignty. Subsequent legislation authorizing the disposal of the public domain, particularly that encouraging private ownership, often required that the land be occupied, improved and/or developed. Legislation establishing national parks, refuges, forests, etc., has typically emphasized protection of resource values. The Taylor Grazing Act (as amended) was passed to "stop injury to the public grazing lands by preventing overgrazing and soil deterioration." This constitutional and legislative framework is supplemented by other legislation and by case law, some of it incorporating the legal concepts of negligence and trespass. While the responsibility to install fencing along a boundary typically resides with the non-Federal neighbor and the Federal Government is immune from State and local government requirements concerning fence installation or design, Federal officials must comply with fencing requirements or standards identified in Federal legislation and regulations.

The Unlawful Inclosures Act of 1885 (UIA), as amended, is applicable to fencing constructed along or adjacent to public lands. This law states, in part, that "No person, by force, threats, intimidation, or by any fencing or enclosing, or other unlawful means . . . shall prevent or obstruct free passage or transit over or through the public lands . . . ." The courts have ruled that the UIA guarantees access to public lands for all lawful purposes and that wildlife access to and use of Federal lands is a legitimate use. In a 1985 decision, the modern applicability of the UIA was discussed as was the relationship of that law to the Taylor Act and the Federal Land Policy and Management Act (FLPMA). The principal findings of the court include the following:

a. "In the years since the 1885 passage of the UIA, the then pressing concerns of settlement and range wars have faded. But present-day concerns have arisen. In the . . . FLPMA . . . Congress set out new goals for the public lands, one of which is that . . . 'the public lands be managed in a manner . . . that will provide food and habitat for fish and wildlife and domestic animals. . . .'"

b. ". . . it is proper to consider FLPMA . . . in light of UIA, especially since Congress as recently as 1984 considered and amended the UIA."

## H-1741-1 - FENCING

## Chapter 2

c. "The [Taylor] Grazing Act itself perpetuates the major purpose of the UIA, namely, access to public lands: 'Nothing contained in this chapter shall restrict the . . . ingress or egress over the public lands in such districts for all proper and lawful purposes . . . 43 USC §315e (1982).' The [Taylor] Grazing Act regulates fencing on public land, and unless fences on private land conform to those standards, the UIA prevents fences which wrongfully enclose public lands."

In this 1985 U.S. District Court Decision (Wyoming No. 85-0136-B), subsequently upheld by the U.S. Court of Appeals (Tenth Circuit), the court did not address the issue of access to public lands by humans. It did discuss an earlier Supreme Court decision which held that in order to build a road, which was in part on private land, and invite the public to use it, the Government had to compensate the owner for the use of his/her land. Section 205 of FLPMA provides authority for the acquisition of public access across private lands. Unless an easement providing legal access is obtained, the public does not have a right to reach public lands without the intervening landowner's permission. On the other hand, while private landowners can control activities on their private lands, they cannot block access to public lands on those public ways where legal access exists. (The BLM does have authority to require that a permittee/lessee grant the BLM access across his/her lands for the purpose of the orderly administration of the public lands when stipulated as a term and condition to receipt of a grazing permit/lease (43 U.S.C. 1752). This authority does not provide for public access and should be used only following consultation with the affected permittee/lessee.)

In summary, the "Red Rim" fence decision (United States v. Lawrence) establishes that legal action may be taken against parties who construct fencing on private lands that could enclose or block access by wildlife to public (Federal) lands. However, common sense and a 1981 Supreme Court ruling both require that we read and give effect to each applicable statutory authority in a manner that, when taken together, best preserves the sense and purpose of each. Therefore, when land use planning decisions indicate that installation of fencing along the boundary of public lands is needed to achieve management objectives, BLM funding of such fencing may be appropriate. However, proposals to construct fences along land ownership boundaries must be coordinated with adjacent landowners and other affected interests. Cost-sharing opportunities should always be explored before expending BLM funds for boundary fencing. In addition, a Grant of Easement and Right-of-Way (Form 2100-2) must be obtained to protect the public (BLM) investments in fences or other improvements constructed on private land (See H-2101-1, Chapter 2. IV.A.4.).

## H-1741-1 - FENCING

## Chapter 3

Chapter 3 - Investment Analysis Standards

Investment analysis is an integral part of activity plan development and is required in most situations. The analysis of all projects in a plan, and of alternative "plans" with differing mixes of projects and management strategies, is necessary to determine the most economic or most cost-effective, package of projects. Analysis on a project-by-project basis is unnecessarily time-consuming, does not provide the information needed to determine cumulative effects, and does not meet the "all costs--all benefits" analysis rule. Investment analysis is also useful in situations where some or all of the benefits cannot be quantified or valued. In situations of this type, the analysis and information provided to decisionmakers should identify the package of improvements that will accomplish management objectives in the least costly manner.

Investment analysis includes the use of economic and other criteria to establish activity plan preparation priorities and to establish the priority of specific improvement and treatment projects associated with those plans (when preparing annual work plans and obligating funds). See Handbook H-1740-1 for general and program-specific investment analysis guidelines. Also see the User Handbook or contact the Service Center user representative for information about the BLM's Investment Analysis Model which is designed for use on IBM compatible personal computers.

## H-1741-1 - FENCING

## Chapter 4

Chapter 4 - Fence Design/Construction Standards

This section describes BLM fencing standards for a number of specific resource situations. Information and standards for several nontraditional types of fencing are also included. Application of these standards requires consideration of the human and animal species using an area; the existence of migration, concentration or other special use areas; and the applicable resource management objectives in land use and activity plans.

Copies of several other documents containing design and construction information applicable to many resource management situations should be available to BLM personnel in every District and Resource Area office. The information they contain must be used in a manner consistent with the standards discussed in this Handbook, as well as other applicable BLM guidance. These publications are:

1. BLM's Engineering Guide Specifications and Engineering Standard Drawings. If copies of these documents are not available locally, first check with the District Office Chief, Division of Operations, then the State Office Chief, Branch of Engineering or contact the Service Center, Chief, Division of Technical Services (YA-672).

2. Fences. Vegetative Rehabilitation and Equipment Workshop (VREW) Handbook, U.S. Department of Agriculture, Forest Service and U.S. Department of the Interior, Bureau of Land Management, October 1987. Copies may be obtained from the Service Center Printed Material Distribution Center.

3. Schemnitz, S., ed. Wildlife Habitat Improvement Techniques. Reprint of Chapter 20, "Habitat Improvement Techniques," from the Wildlife Techniques Manual, Fourth Edition, 1980. The Wildlife Society, Inc., Washington, D.C.

A. Gates and Cattleguards. To ensure adequate public vehicular access, gates and/or cattleguards should be installed in fences on every regularly used road or trail. Additional gates should be installed along fences where access is needed. As a general rule, at least one gate should be installed every mile and in sharp angle corners. Cattleguards with an adjacent gate must be installed on heavily used roads. Where there is a need for access by equipment exceeding the normal legal width (i.e., wheat combines, road graders, etc.), install wider adjacent gates to accommodate them. Where practical, gates at cattleguards should be installed 50 to 100 feet off the road to minimize crowding of livestock onto the cattleguard and to keep the road open to traffic. Gates across roads should be at least 16 1/2 feet wide or as wide as the maintained portion of the road whichever is greater. Acceptable types of wire gate opening devices are shown in Illustration 3.



## H-1741-1 - FENCING

## Chapter 4

1. Wire Gates. Wire gates of smooth wire or barbed wire may be used to obtain the appropriate degree of control. One of the opening devices shown in Illustration 3, or a similar one, is required on new wire gates so that they may be opened and closed safely and with a minimum amount of effort. Where large numbers of livestock periodically pass through a fence, such as in stock driveways, consider building two standard gates with a brace panel or post between them.

2. Pole Gates. Pole gates are appropriate and should be considered for use at administrative sites, along scenic roads, and at recreation areas.

3. Board Gates. Gates constructed of boards or planks should normally be used only for corrals or similar management facilities.

4. Metal Gates. Metal gates may be appropriate in many situations. Either do not use metal gates or take care to mitigate visual/aesthetic impacts where that is a management concern.

5. Cattleguards. Prefabricated cattleguards are often preferred because of cost, maintenance, and utility advantages. Treated wood timbers or concrete bases should be used in cattleguards. Prefabricated bases may be used unless State or county standards require cast-in-place concrete bases. Installation at a 90-degree angle to the road and on a slight rise is preferable. Do not install them on curves, at the bottom of sharp dips, or in blind spots. Keep the fence straight on each side of the cattleguard for at least 60 feet. Curves in a fence line sometimes create a trap, or where livestock collect as they drift through the area. Curved fencing adjacent to a cattleguard may also tend to direct livestock onto the cattleguard. Proper alignment of the fence will usually eliminate both of these problems.

6. Stiles and Fence Ladders. Stiles, ladders, or walk-through passes (Illustration 3) should be provided where fences bisect pedestrian routes. Stiles or walk-through passes should be considered on study exclosures and at water facilities where frequent use could cause maintenance problems.

B. Public Lands Identification. Where fences are constructed across public access roads and trails, signs should be placed on the fence to identify land ownership. This is particularly important where fences are constructed along public-private ownership boundaries since this will help keep the unknowing public off private lands. Owners of the private land may cooperate by specifying whether or not a certain activity, such as hunting or fishing, is permitted on their private property.

## H-1741-1 - FENCING

## Chapter 4

C. Grounding Wire Fences. Wire fence should be grounded to provide protection from lightning. Installation of a grounding device on wire fences is particularly important on fences constructed under a high voltage power line and on wire fences in heavy recreational use areas, especially if only wood posts are used. Steel posts may be poor grounding devices, unless they penetrate to a depth that assures permanent contact with moisture. An 8-foot electrical grounding rod penetrates deeply enough to provide a satisfactory ground in nearly all situations.

D. Standards for Big Game Habitat. Standard fencing for areas inhabited by resident and migratory populations of pronghorn antelope, javelina, deer, elk, moose, and bighorn sheep are depicted in Illustrations 1 and 2. These fences incorporate the fence heights and wire spacings described below and are designed to allow certain big game animals to safely negotiate fences in most circumstances. In areas where slope, snow accumulation, or muddy conditions restrict big game movements, the adjustable or let-down fences depicted in Illustrations 6 and 7 can be used if fence realignment is not a viable alternative. Other options to assist in big game fence negotiation include underpasses, overpasses, and additional gates along important wildlife crossings and around water sources. Where new fences are constructed across wildlife migration routes or through heavy use areas, they should always be flagged with a temporary material (e.g., strips of cloth, survey flagging tape, etc.) between every other post. This will enable big game animals to become familiar with their location without causing long-term visual impacts. More restrictive fence designs (i.e., around study exclosures, culinary water supplies, spring boxes, settling ponds at oil wells, etc.) may be used when resource management objectives identify the need to exclude wildlife from an area.

1. Pronghorn Antelope and Javelina Habitat.

a. Limitations. Woven wire fences and 5- and 6-strand barbed wire fences limit antelope and javelina use of available habitat. Woven wire fences, in particular, restrict both antelope and javelina movements and are extremely hazardous when they prevent antelope migration to winter range or eliminate access to water sources in the summer. Antelope normally do not naturally attempt to jump or go through barbed wire fences, but prefer to go under them. Small fenced areas discourage antelope use. Moreover, javelina do not jump fences and have problems negotiating closely spaced barbed wire fences.

## H-1741-1 - FENCING

## Chapter 4

b. Standards for Pronghorn Antelope. (1) While adult antelope do have an inherent physical ability to jump over some fences, many of them are unaware of this and jump only when frightened. Research results indicate that jumping is a learned behavior. Fawns and some adults do not jump even when extremely frightened. Most antelope prefer to go under or through fences and a 16-inch ground-to-bottom-wire clearance provides adequate space for adult and young animals to pass under fencing. A three-wire fence such as that shown in Illustrations 1 and 2 is the preferred design in pronghorn antelope habitat areas. Two more restrictive, four-wire fences are also illustrated. The 40-inch high fence should be used only in situations where greater restriction of livestock movement is needed. All three designs have a 16-inch ground to bottom wire space.

(2) In areas where a tight fence is needed, it should not exceed 32 inches in height. Research data indicate that when a 32-inch woven wire fence is used, some adult animals and most fawns did not or could not jump over it. Thus, woven wire should not be used in antelope habitat areas unless all habitat requirements are met within the fenced area or an alternative means of providing for antelope movement is used. These include the use of antelope passes, let-down or adjustable fencing, and standard cattle-guards in fence corners. Antelope passes have limited effectiveness (Illustration 5) since antelope moving along a fence line often go by the passes without noticing them. Let-down or adjustable fencing is effective only if it is adjusted at the proper times. The location of cattleguards in fence corners is quite effective but fawns do initially have difficulty in crossing them. Cattleguards have not been widely used in this manner, however.

(3) Fences constructed in antelope habitat must remain "loose" without stays or with the stays not connected to the bottom wire. A smooth bottom wire should be used. Waters used by antelope should remain unfenced. However, when there is a need to exclude some species for water quality or other reasons and provide for use by antelope, the water source and an area of at least 3-5 acres of fairly level terrain should be fenced to exclude some or most other species. A higher fence with closely spaced wires, but with a 16-inch bottom clearance, is one means of excluding other larger species.

## H-1741-1 - FENCING

## Chapter 4

c. Areas of Seasonal Pronghorn Antelope Movement. When resource management objectives identify the need for fencing across seasonal antelope migration routes, a three-wire fence should be used (see Illustrations 1 and 2). Antelope frequently use those sections of a fence with the greatest ground-to-bottom wire clearance (these may be only 1 to 2 inches higher than the rest of the fence). In areas where snow accumulation, muddy conditions or high stress circumstances are common, do not use a four-wire fence since antelope cannot readily pass through it. Do not use woven wire fencing across migration routes. The standard three-wire fence design can hinder movement and may prove lethal in some situations. Also consider the following options: let-down; swing-back; and adjustable fencing; double gates; antelope passes; and cattleguards (see Illustrations 5-9). If domestic sheep use the area, consider one of the four-wire fences shown in Illustrations 1 and 2. Good project planning, including an assessment of conflicting management objectives, will help determine which alternative is best suited to a specific "difficult" situation. As noted above, each alternative has its limitations.

d. Standards for Javelina. Fences within javelina habitat areas must have a 12-inch ground-to-bottom wire clearance. This is particularly important where woven wire or other "sheep-tight" fencing is used. A fence with the 12-inch bottom clearance, a top height of 32 inches, and several closely spaced strands of barbed wire effectively controls sheep and meets the needs of javelina as well as those of other wildlife species (e.g., most antelope and deer can jump over a 32-inch fence).

2. Deer, Elk, or Moose Habitat.

a. Limitations.

(1) Woven wire, 5- or 6-strand barbed wire fences and fences exceeding 42 inches in height all pose serious negotiation problems for deer. A 48-inch woven wire fence topped with two strands of barbed wire (total height of 52-56 inches) significantly increases adult deer mortality and prohibits fawn and yearling negotiation. This fence, surrounding a water source, can be lethal during periods of drought. In areas where cattle are gathered by water trapping, construct about 30 percent of the waterhole trap with fencing suited to negotiation by deer or elk. Other factors affecting negotiation of fences include the age and condition of deer and elk, wire tautness, and the physical setting of the fence. Fences constructed next to borrow pits, on steep slopes, and in areas where snow accumulates, may not be negotiable by deer, elk, or moose. Illustration 4 shows how slope affects effective barrier height. When the lower strands of wire are both close to the ground and to each other, they impede the movement of fawns and yearlings which tend to go under or through a fence.

## H-1741-1 - FENCING

## Chapter 4

(2) Normally, deer jump with their hind legs forward. If the top two wires are too close together or loose, deer often entangle their hind legs, resulting in broken legs, entangled animals dying of starvation or shock, and broken fences. Elk jump the same way, but usually move on after breaking the fence or injuring themselves. Within elk herd movement areas, fence damage can be extensive.

b. Standards. Illustrations 1 and 2 depict fencing standards to be used in deer, elk, or moose habitat.

(1) Within big game ranges inhabited by deer, elk, and/or moose, fences with a top height of 38 inches and a 12-inch space between the two top wires are preferred. The standard placement and number of fence stays are shown in Illustrations 1 and 2. In areas where deep snow is common, use wood rather than metal stays (preferably juniper) to maintain spacing and mark its location. To minimize deer mortality, all fences with a top height of 38 inches or greater must have the 12-inch spacing between the two top wires. Use of a smooth bottom wire and a bottom space of 16 inches will reduce injury to fawns and yearling deer who often try to move between the lower wires. Use of a 40-inch high fence in deer habitat is acceptable, if necessary, except where sloping terrain, deep snow, or a borrow pit reduces the effective capability of deer to jump a fence. Lowering the top strand to about 25 inches from the ground during critical seasons will allow deer to move over it in most situations.

(2) The standards reflected in Illustrations 1 and 2 include fences which may be used around water sources. To enhance wildlife use of a water facility, especially one designed to provide water inside the fenced area for wildlife and outside for livestock, include at least 3 to 5 acres within the fence to provide ample space for deer passage and movement.

(3) Fences along roads and highways should be constructed in a manner that provides room for big game animals to jump from level ground. This can be accomplished through selective placement of the fence or grading the area next to the fence. One alternative is to adjust the effective barrier height; another is the installation of big game passes at appropriate intervals. Another alternative is to set back the fencing along roads about 300 feet from the road. This will minimize animal/vehicle collisions by providing space for animals and drivers to observe one another prior to crossing. If the combined presence of animals and heavy traffic constitutes an unacceptable hazard, use restrictive fencing in combination with overpasses and underpasses.

## H-1741-1 - FENCING

## Chapter 4

c. Deer, Elk, or Moose Seasonal Migration Areas. If fencing is needed to accomplish resource management objectives in seasonal movement areas, a three-wire fence or post-pole-and-wire fence, such as that shown in Illustration 11, should be used. Sections of let-down or adjustable fence, installed at appropriate intervals, may be an acceptable alternative.

3. Bighorn Sheep Ranges.a. Desert Bighorn Sheep Ranges.

(1) Limitations. Fencing in bighorn sheep habitat can limit bighorn use of available habitat and increase mortality. Fencing around water sources and seasonal ranges typically causes the greatest problems. Moreover, bighorns do not successfully compete with burros for water, when supplies are limited and burro use is high. The principal limitation of fencing in areas having desert bighorn sheep is that they typically try to go through or under fences. Larger rams can become entangled when trying to move between the strands of wire (the wire becomes caught inside the curl of their horns). Death typically results from fighting the fence unless the wire is weak and breaks.

(2) Standards. The standard in desert bighorn sheep ranges is a fence with an 18- to 20-inch clearance between the ground and the bottom wire, a 15-inch space between the bottom and second wire, and a 4-inch space between the two top wires (see Illustrations 1 and 2). A top wire height of 37 to 38 inches is also acceptable within deer and elk habitat. If the ranges of desert bighorn sheep, elk, and deer overlap and conflicts arise between design standards suited to these species, the requirements of desert bighorn should normally take precedence.

Rail fence (Illustration 2) has been found effective in excluding burros and cattle from desert bighorn watering areas. Two quite similar designs have been suggested, both using 2-inch minimum diameter rails (steel pipe or wood of similar strength). One design 1/ calls for a bottom spacing of 20 inches, 16 inches between the bottom and middle rails and 4 inches between the middle and top rails for a top height of about 46 inches. The second design 2/ calls for an 18-inch bottom space, 12 inches between the bottom and middle rails and 6 inches between the middle and top rails with a top height of 42 inches. Rail fencing may not be compatible with wilderness area visual standards. To minimize anxiety of bighorns while watering within an enclosure, the area should contain a minimum of 3-5 acres. An alternative means of protecting bighorn watering areas is to locate water developments in a manner that provides a 2-mile separation between the livestock and bighorn water sources.

1/ (1971 Trans. Desert Bighorn Council)

2/ (G. Hammet, Ariz. F&G Dept. pers. commun., March, 1988)

## H-1741-1 - FENCING

## Chapter 4

One method of allowing desert bighorn access and restricting burro use is to enclose a portion of rimrock, negotiable by bighorns but not by burros, within the fenced water area. Another possibility is to pile rock in one or more corners of an enclosure, which allows wild sheep, but not burros or livestock, to negotiate the fence. Where wild sheep, burros, and livestock all require water in the same immediate area, water developments for burros and livestock must be located away from the bighorn sheep water facility.

b. Other Bighorn Sheep Ranges. Observations in the Shoshone National Forest in Wyoming indicate that about 90 percent of the bighorn sheep fence crossings there were by jumping 3/. The fence used there includes two barbed wires with the bottom wire being 16 inches from the ground and a space of 12 inches between the two wires. The fence is topped with a 4-inch wood rail for a top height of 40 inches (see Illustration 11). It appears that bighorn sheep treat the top rail much as they would a rock ledge and adjust their jumping patterns accordingly. They sometimes touch the top rail as they jump the fence. Lambs pass through the 16-inch bottom spacing. Where greater restriction is needed, a third wire can be added, reducing the ground-to-bottom wire clearance to about 12 inches. A smooth bottom wire should always be used in this fence configuration. This fence, with three wires and a pole along the top should be used only where absolutely necessary.

A more restrictive fence that has been used successfully with desert bighorns in Arizona 4/ may also have application on other bighorn ranges. The design consists of a smooth bottom wire 16 inches from the ground, two barbed wires spaced 6 and 14 inches, respectively, from the smooth bottom wire and a smooth top wire 12 inches above the upper barbed wire for a top height of 42 inches. The close spacing of the lower three wires, in combination with the 16-inch space at the bottom, seems to deter bighorn sheep from sticking their heads through the fence and becoming trapped. Use of the less restrictive designs are preferred. (Some biologists also believe that fencing in bighorn areas should have a top height of 38 inches.)

The pipe or pole fences discussed above, that exclude burros from desert bighorn watering sites, are effective in all areas except where domestic sheep use exists. Where there is a need to exclude domestic sheep, either use a tight but low fence or provide for bighorn passage with a rockpile in at least one corner of the fence around the watering area.

E. Standards for Wild Horses and Burros.

1. Cattleguards. Cattleguards in wild horse herd management areas should be constructed with a steel reinforcing rod (rebar) between each rail to prevent the horses from stepping between the rails and becoming caught.

3/ (J. Sanders, personal comm., April 1988)

4/ (G. Hammett, Ariz. F&G Dept., pers. comm., March 1988)

## H-1741-1 - FENCING

## Chapter 4

2. Gates. Double gates are preferred in horse and burro use areas since they can be pulled back from the opening and attached to the adjoining fence.

3. Fences. When a horse becomes caught or trapped in wire fencing, the reaction commonly includes pulling and thrashing in an attempt to break away and run free. While this is similar to the reaction of wildlife caught in a fence, the size and shape of horses' hooves prevent the wire from slipping off as easily as with deer, for example. Loose wires on or near the ground present a particular hazard since horses may not see them until they are caught in them. If let-down or adjustable fences are constructed within wild horse and burro use areas, they must be designed to avoid injury to the animals that move through them.

Fences constructed with steel pipe or with wood poles are readily visible to moving animals and have proven to be effective in excluding horses and burros from an area, when this is an objective. Buck-and-pole or post-pole and wire fencing, with adequate gates for passage through them, are particularly suited to areas where seasonal exclusion is desired and safe passage is needed the rest of the year (see Illustration 11).

F. Standards for Recreation Sites. Fences partially or fully enclosing recreation sites should be designed as an integral part of the site plan (see Manual Section 8323.33 - Project Plan Concept and Design Parameters, for additional guidance). Management objectives will determine what type of fence is suited to a particular site. Function, aesthetics, effect, cost, and safety are to be considered in making that determination. A buck-and-pole fence constructed from native wood materials in the area, if available, is a good alternative. (See Illustration 11.) Although the use of barbed wire fence is not precluded, generally it should be avoided in areas where heavy public use is common. If a combination of poles and barbed wire is needed or desirable, consider the post with pole and wire fence shown in Illustration 11. Also consider the use of walk-through passes or stiles (see Illustration 3). Conventional barbed wire fences should be located some distance away from developments in a recreation site to minimize potential problems, particularly when family use (with children) is common.

1. Buck-and-Pole Fences. Buck-and-pole fences, as shown in Illustration 11, may be desirable along fishing streams for their aesthetic value and because there is less chance for fishermen to become entangled. This type of fence is also effective in areas where snow breakage and falling timber cause problems or if there is considerable winter elk use.

2. Post-Pole and Post-with-Pole-and-Wire Fences. These fences (see Illustration 11) may be used for aesthetic value around recreational and administrative sites, along scenic roads, or for special wildlife applications. A pole rail on top of the posts may help reduce maintenance around horse pastures, in areas of high big game movement or migration, and in areas heavily used by people.



## H-1741-1 - FENCING

## Chapter 4

G. Bison Range Fencing. Proper design and location of fences around and within bison use areas is critical since bison sometimes pay little heed to fencing. Several proven designs exist that provide effective control of buffalo and minimize maintenance costs.\*

On small ranges (less than 10,000 acres), a "buffalo-tight" fence constructed from two spans of 47-inch woven wire (guage #11), overlapped about 4 inches to give a top height of 7 feet, 6 inches is recommended (similar to the fence at the top of Illustration 16). For interior or cross fencing, a 5-foot tall fence consisting of six wires, with the bottom wire smooth and placed 16 inches from the ground, has proven effective (see Illustration 17). An alternative to this consists of one band of 47-inch woven wire, with a 16-inch bottom-to-ground spacing (see Illustration 17).

On large buffalo ranges (10,000 acres or greater) the interior fence designs discussed above are generally adequate for exterior and interior fencing. Their height, "tight" spacing of wire and bottom clearance of 16 inches, requires that wildlife move under them. While this is satisfactory for antelope and most deer, bighorn sheep need a slightly larger space (18 inches) as do some large mule deer.

An alternative interior fence design that is generally suited to movement of all wildlife species is an electric fence with a top height of 38 inches. A design currently in use consists of a modern, high-voltage (New Zealand type) electric fence having three wires with only the top wire electrified. This type of fence is sometimes used with both the top and bottom wires electrified. Bison can jump over this electric fence if disturbed or pushed. Animals not accustomed to electric fencing may initially push it down. When steps are taken to help bison (or other species) develop a respect for electric fencing and "breachy" or rogue animals are culled, the design is quite effective.

H. Domestic Livestock Fences. Fencing is commonly used to control domestic livestock to achieve safety and vegetation management objectives. The standard BLM fence design for control of cattle only, consists of a four-wire (barbed) fence with a 42-inch top height and wire spacings of 16, 6, 8, and 12 inches.

\*The standards for bison, as discussed in this section, are based in part on information from the National Bison Range, as provided by Jon Malcolm, U.S. Fish and Wildlife Service, Moise, Montana.

## H-1741-1 - FENCING

## Chapter 4

For control of domestic sheep, the standard fence design consists of a barbed wire 2 inches from the ground, 24-inch woven wire spaced 2 inches above the bottom wire and two barbed wires with spacings of 2 and 8 inches, respectively, above the woven wire (see Illustrations 1 and 2).

Where cattle and/or sheep control is needed within the habitat areas or ranges of wildlife, wild horses, or bison, the design standards for the applicable animal species should be incorporated in the fence design. Adjustments in design to control large (tall) cattle may occasionally be appropriate. Use the project planning and analysis procedures to ensure that site-specific management objectives and mitigation measures are incorporated in fence design.

Effective control of domestic livestock is a function of several factors other than fence design. They include selection of animals with desirable behavior characteristics, culling the "breachy" animals, movement (herding) of livestock when forage utilization reaches acceptable levels, etc. In sum, fencing is only one of several livestock management "tools."

I. Riparian Area Fencing. Fencing is commonly associated with the management and improvement of riparian areas. However, development and application of a management prescription for the full management unit or area, including both the riparian and associated upland range sites, is a prerequisite to project planning. After riparian and other management objectives are developed, the structural projects and land treatments needed to achieve them can be identified and installed. Projects such as off-stream water developments, seeding, etc., and management practices such as herding, salt placement, short-duration grazing, etc., should also be considered in conjunction with, or instead of, fencing.

Since fencing along riparian areas may have negative as well as beneficial effects, careful consideration of its location and design is necessary. Temporary fences may be used to exclude specific animal species or uses from an area during rehabilitation. Temporary fencing should be removed when monitoring data indicate that applicable objectives have been met. Permanent fencing should encompass an area large enough that it can serve as one pasture or use area within the larger management unit. The design of permanent fencing must be based on the standards applicable to the species that use the area. Use of the riparian area by wildlife and/or livestock may then occur periodically by providing access through gates, take down fencing, etc. In sum, consideration of the "larger area," all human and animal uses the area receives, and the advantages and disadvantages of each alternative is necessary.

## H-1741-1 - FENCING

## Chapter 4

J. Nontraditional and Other Types of Fences. During the past couple of decades, several "newer" or "special" types of fence have been developed and gained acceptance for use in certain types of situations. Although they have been mentioned earlier in this Handbook, they deserve additional discussion because of their effectiveness in certain livestock and wildlife use situations and because they may reduce the cost of fencing. They are discussed briefly in the following sections. See the reference handbook Fences for additional information.

1. Suspension Fences. This type of fence should be considered for use along interior pasture boundaries, and can reduce fencing costs on flat or undulating terrain. Its principal advantage is that it typically has lower construction and maintenance costs. It also stands up well in moderately heavy snow and big game areas. Suspension type fencing can be constructed from either barbed or smooth wire. Illustration 12 shows two suspension fences, one constructed of smooth wire and one with barbed wire. The line posts may be spaced 60-80 feet apart; however, the proper installation of brace posts or "fence strainers" is critically important. Special clips or staples must be used to allow movement of the wire through them. Smooth-wire fencing is also discussed below.

2. Electric Fences. An electric fence is most effective on moist sites and least effective on dry, rocky sites. Recent technology has greatly improved its effectiveness at a cost usually less than traditional fencing. Two-wire and three-wire electric fences are now used effectively to manage livestock grazing in all areas.

a. Short-Time Holding. To contain livestock in one pasture for a short time (e.g., short duration grazing) or to exclude livestock from an area for a short period, consider using an electric fence (see Illustration 13).

b. Design for Cattle. A well-tested spacing, which has proven effective for cattle, consists of two smooth wires, 3 inches apart, constructed with a top height of 24 to 30 inches from the ground. The top wire is typically "hot" and the "cold" bottom wire serves as the ground wire. This fence interferes very little with wildlife movement and has low visibility. It can be easily crossed on foot by adults, or with a vehicle, by merely standing on it to push the wires to the ground. This is possible because the wires are stretched to a 200-lb. tension and are free-running at all posts. When an electric fence is first installed, it should be flagged to accustom animals to its presence.

## H-1741-1 - FENCING

## Chapter 4

c. Smaller Livestock or Mixed Groups. For areas being used by smaller livestock or by a mixture of cattle and smaller animals, the same type of fencing is effective when the bottom wire is lowered to between 16 and 24 inches from the ground. Three strands of wire may be needed. Electric fencing may be authorized for use around small or temporary exclosures where a specific need or management objective has been identified. Before using fencing widely around watering areas, assure that they effectively exclude the animals to be excluded and allow the other species access to the water as desired.

3. Smooth-Wire Fences.

a. Applications. Smooth wire can be used for both traditional and suspension type fences. Recent research and demonstration projects indicate that high-tensile, smooth-wire fences with numerous strands (six or more) will control livestock if the wire spacing and fence height are appropriate (Illustration 12). Topography and wildlife use in an area must be considered during project planning, since control of big game movement may also occur.

b. High-Tensile Wire. High-tensile smooth wire is recommended in place of barbed wire on suspension fences for several reasons. While smooth wire yields many more feet per pound than barbed wire, the potential cost benefit is partially offset by the need for more strands of wire. High-tensile, 12.5-gauge triple-galvanized smooth wire will last 35 to 50 years and has up to twice the strength of barbed wire (which must be prestretched to maintain its tensile quality). Line posts can be spaced about 60 feet apart, with brace or strainer assemblies about one-quarter mile apart. Special clips or staples are needed to allow the wire to move through them when it is stretched. The use of sleeves to join two ends of wire saves time and keeps the fence strong, since knots in wire can reduce strength up to 40 percent. Stays or spacers made of either wood or metal, placed at 10-foot intervals with one end on the ground, are recommended. See Illustration 10 for an example of a smooth-wire fence and Illustration 14 for an example of a strain insulator that may be used with high-tensile and adjustable fences.

## H-1741-1 - FENCING

## Chapter 4

4. Adjustable Fences. Raising or lowering one or more wires can allow big game passage during periods when livestock are not present, as shown in Illustrations 4 and 7. Adjustable wire fences can allow nearly total freedom of movement by big game through any desired length of fence. Fence maintenance problems caused by drifting snow or big game can be greatly reduced, if not eliminated. Only the problem wires need to be moved. All other wires can be fastened securely to the posts. Fastening mechanisms used on adjustable fences are shown in Illustration 8. Fence adjustments can be made about as rapidly as a person can walk the fences. Although only antelope and deer are depicted in Illustrations 6 and 7, many big game species can be accommodated by this type of fence. Clearance under a fence can be greatly enhanced by merely lifting the bottom wire up one position. Illustration 7 depicts two adjustments, one of which allows near total freedom of movement for antelope. Lowering the top wire of a 42-inch fence by 17 inches and the second wire by 5 inches reduces the barrier height to about 25 inches, and creates a fence that should be negotiable by deer under virtually all conditions.

5. Let-Down Fences. A listing of adjustable and let-down fence projects identifying the dates when the fences should be raised or lowered should be maintained in each Resource Area Office. The responsibility for maintenance and annual adjustments should be assigned prior to construction and periodically monitored. Let-down fences, as shown in Illustration 9, are used where entire sections of a fence are to be laid horizontally on the ground. This fence can be used in areas of deep snow or where a fence crosses a big game migration route. Several let-down fence designs have been used or suggested. One of these uses a wire loop at the top of the posts to hold the stay in place and replaces the lower wire loop with a pivot bolt. This allows the fence to be let down and erected more easily. Let-down fences may be designed to permit pulling the let-down section back against a section of standing fence. The fence must be designed to provide for adjustments in wire tension. When the wire is so taut that it does not lay flat on the ground or is so loose that loops of wire are formed, a serious hazard is created for people and animals crossing it.

6. Study Exclosures and Enclosures.

a. Exclosures. Study exclosure fences, such as those shown in Illustration 15, may be needed to monitor or evaluate the effects of use by certain types or species of animals on vegetation. One or more of the fences shown in Illustrations 1 and 2 can be used to exclude livestock from study areas. Where big game use is permitted but livestock are to be excluded, a post-pole-and-wire fence is recommended.

## H-1741-1 - FENCING

## Chapter 4

b. Enclosures. Occasionally, there is a need for enclosures to confine wildlife to a small area in connection with wildlife transplants, etc. Various designs have been used in differing areas, depending on the species involved, terrain, economic considerations, etc. Those used for bighorn sheep and deer are often similar to the deer-proof fences discussed below. Where unusual conditions or factors must be addressed, seek assistance from State wildlife personnel and State Office biologists.

7. Deer- and Elk-Proof Fences. Deer/elk-proof fences may be required to restrict movement or use in certain areas by these animals (e.g., to prevent their movement onto interstate highways). Several different types of deer-proof fences are in use throughout the West. Some typical designs are portrayed in Illustration 16. Use of this type of fencing may need to be combined with the construction of overpasses or underpasses.

8. Fence Drainage Crossings. In places where watershed conditions create the potential for a large amount of runoff, the effects of which are concentrated in arroyos, canyons, ephemeral streams, creeks, and rivers whose flow levels vary substantially, periodically damaging the fencing that crosses them, special drainage crossing structures (sometimes called "water gaps") should be used. The need for periodic reconstruction or major maintenance can be eliminated or substantially reduced if this type of fence structure is used. Since no two field situations will ever be identical, there is no "single standard" for their design. Several types are included in the Engineering Standard Drawings and several designs are illustrated in the reference handbook Fences.

9. Other Special Management Situations. Other situations requiring unusually restrictive fence designs (i.e., five or more strands of wire or woven wire) include gathering/shipping areas, lambing pastures, protective fencing around water sources where animal use is to be excluded,\* designated research or natural areas, some allotment boundary situations, etc. Use of unusually restrictive fencing across long distances or to encompass large areas of land shall not occur unless the analysis and decisions documented in the applicable RMP/EIS identifies a need and guides the concurrent installation of mitigation measures.

\*Protective fencing around water sources may be needed to ensure that the facilities located there continue to function properly and for water quality and health reasons. In most of these situations the water is delivered to a drinking facility (i.e., trough) located nearby.

## H-1741-1 - FENCING

## Chapter 4

K. Preservative Treated Posts. Wood posts treated with commonly used preservatives (pentachlorophenol, creosote, and inorganic arsenic) may be purchased and used in BLM fence construction. There is no current ban on the use of these posts. There are handling and use precautions or restrictions. While the BLM normally purchases only pressure treated posts, nonpressure treated posts may be purchased and used if they meet net retention and penetration requirements for the wood species involved. Moisture content should not exceed 25 percent at depth of required penetration when measured with a resistance-type meter with insulated needles. Treated lumber and posts must bear a quality mark or label designating conformance to the American Wood Preservers' Bureau (AWPB) standards. (AWPB standard P 5: Fence Posts-Preservation Treatment by Pressure Processes, identifies net chemical retention and penetration requirements.)

## H-1741-1 - FENCING

## Chapter 5

Chapter 5 - Modification and Removal of Existing Fence

When the design, condition, or usability of a fence is not in conformance with management direction or the fence presents an unacceptable impediment to accomplishing identified resource management objectives, it should be modified or removed. Examples of problem situations include:

- o Seasonal, daily, or other movement of big game is restricted.
- o Fences do not control livestock movement.
- o Better public access is needed.
- o Wild horse, big game, or livestock movement onto highways regularly leads to accidents.
- o A fence was not constructed to contract specifications or the stipulations of an authorization.
- o A fence is no longer needed to achieve management objectives.
- o A fence as currently designed and constructed has unreasonably high maintenance costs.

A. Criteria. Adverse impact on big game animals, ineffectiveness in controlling livestock, and access concerns are all reasons for proposing modification and removal. For example, a fence may restrict or alter the movement of antelope, javelina, deer, elk, moose, bighorn sheep, bison, etc. If animals become entangled while attempting to cross under, over, or through a fence, it must be modified to allow wildlife passage. This is essential for the young-of-the-year animals who are hard pressed to negotiate certain livestock fences, and may be necessary to provide wildlife access to water sources. Most situations will involve balancing competing and/or conflicting management objectives and concerns, including the criteria of cost-effectiveness.

B. Responsibility for Modification. The party (or program) requesting or proposing the modification is normally responsible for its installation. To the extent possible, public concern and input from other agencies should be combined with BLM consideration of fence modification needs during management plan development. The need to modify, remove, or install fencing should also be assessed during the periodic activity plan evaluations. Proposals made during plan implementation must conform with existing management direction.



## H-1741-1 - FENCING

## Chapter 5

If a fence was improperly designed or constructed and the maintenance of it would be difficult, the BLM has a responsibility to either make the needed modifications before assigning maintenance responsibility or to assign it "as is." New fence projects should be designed and installed to a standard that will avoid the need for future modification. Failure to comply with the guidance on internal and/or external coordination by a project proponent does not shift the responsibility for funding to the entity or program who first notices the problem.

Permittees are responsible for the modification of projects constructed under authority of a range improvement permit. Modification may be required as a result of improper design, construction, or when needed to achieve management objectives for the area affected (43 CFR 4130.6-2).

C. Responsibility for Removal. The owner of the fence is normally responsible for its removal and any necessary rehabilitation. Decisions to remove or abandon fences must either evolve from management plan development or be in conformance with existing management direction, if the decision to remove a fence occurs as a result of an activity plan evaluation.

NOTE: Also see Handbook H-1740-1, Chapter 4, "Maintenance Modification, Reconstruction and Abandonment Guidelines" and Chapter 5, "Guidelines on Unauthorized Improvements and Treatments."

## H-1741-1 - FENCING

## Chapter 6

Chapter 6 - Maintenance

Fences must be maintained in a usable condition, consistent with the original as-built standards or those standards established following a decision on fence modification. The principal beneficiary has maintenance responsibility. This responsibility must be identified in the authorizing document and recorded in project and activity plan files. Project maintenance information must be included in the Rangeland Improvement Project System record created following installation. Maintenance inspection schedules should be developed using this project inventory data. Performance of maintenance should occur as needed and be recorded (use Form 1740-1, for maintenance inspections). Failure to maintain a project may result in loss of certain use privileges. Maintenance standards should be discussed with the responsible party and the lack of maintenance reported to Area Managers.

An inventory of let-down and adjustable fences (including gates installed to provide for wildlife or other animal movement) must be maintained in District and/or Area Offices. The responsibility for adjusting or putting each fence up or down must be identified in Cooperative Agreements, Range Improvement Permits, and/or activity plan files. The BLM personnel should visit each site to assure that the appropriate adjustment has been made, when a cooperator has that responsibility. (See H-1740-1, Chapter 4, for additional discussion of maintenance guidelines.)

## H-1741-1 - FENCING

## Chapter 7

Chapter 7 - Reconstruction

Reconstruction of fences must conform with the standards and criteria in this Handbook. Since modifications and exemptions are permitted under certain circumstances and management guidance is subject to change over time, use the project planning checklist to assure that replacement fence is designed and constructed to be consistent with current management direction. Responsibility for fence reconstruction rests with the owner. Where shared ownership exists, consultation between owners is necessary.

Major reconstruction or replacement should occur only when construction or design inadequacies, or the normal effects of use and environmental influences, leads to sufficient wear and deterioration that repair would cost more than 50 percent of replacement. Also see Handbook H-1740-1, Chapter 4, for a discussion of reconstruction guidelines.

## H-1741-1 - FENCING

Glossary of Terms

-A-

allotment: an area of land designated and managed for grazing by livestock. An allotment may include land not suitable for livestock grazing.

Allotment Management Plan (AMP): a program document which prescribes the manner in, and extent to which, livestock grazing is to be conducted and managed to meet multiple use, sustained-yield, economic and other human or resource objectives as determined through land use planning. Existing and planned improvements, and the responsibility for their maintenance, must also be identified. Consultation, cooperation, and coordination with the permittee(s), lessee(s), and other affected interests are required.

antelope pass: a cattleguard-like structure intersecting a fence as shown in Illustration 7. The pass capitalizes on the ability of antelope to jump laterally as opposed to their reluctance to jump over high obstacles. An example of an antelope pass is a 5-1/2-foot x 6-foot metal grill with 13, 5-1/2-foot parallel bars on 6-inch centers fastened to steel supports.

-C-

critical habitat: any air, land, or water area (exclusive of existing manmade structures or settlements which are not necessary to the survival and recovery of a listed species) and constituent elements thereof, the loss of which would appreciably decrease the likelihood of the survival and recovery of a listed species or a distinct segment of its population. Constituent elements of critical habitat include, but are not limited to: physical structures and topography, biota, climate, human activity, and the quality and chemical content of land, water, and air. It may represent any portion of the present habitat of a listed species and may include additional areas for reasonable population expansion. (See Manual Section 6840.)

crucial habitat: portions of the habitats of sensitive species which, if destroyed or adversely modified, could result in their being listed as threatened or endangered pursuant to Section 4 of the Endangered Species Act (ESA) or in some category implying endangerment by a State agency or legislature. Examples of crucial habitat areas are booming grounds, nesting areas, brood rearing areas, winter ranges, migration routes, anadromous fish spawning grounds, fish rearing water, or any habitat necessary to the survival of the species in question at important periods of their life cycles.

H-1741-1 - FENCING

-D-

destruction or adverse modification: any action which would have a deleterious effect upon the habitat of a sensitive or officially listed species to such an extent that the loss would pose a threat to its continued survival or recovery in the wild.

-E-

endangered species: any species of plants or animals which is in danger of extinction throughout all or a significant portion of its range.

enclosures: areas of land enclosed by a fence for the purpose of excluding all animals or specific species or groups of animal. Enclosures serve as control areas where biotic factors can be measured, recorded, and evaluated. These can be compared with plots in adjacent areas to which the excluded animals do have access.

-F-

federally listed species: those species of plants or animals classified by the Secretary of the Interior or the Secretary of Commerce as threatened or endangered pursuant to Section 4 of the ESA.

fence: a structural device usually constructed of steel wire, rails, posts, or other material supported by posts, that contains or excludes all or certain animals from a specific area for management purposes, to protect public values and/or the general public from safety hazards.

-H-

habitat: the sum total of environmental conditions required in a specific area or site occupied by an animal or plant population, i.e., food, cover, water.

habitat management area: a specific area which encompasses, as a minimum, the ecosystem determinants and biological requirements for those fish and wildlife species living within the area.

habitat management plans (HMP's): plans normally written for habitat management areas. (See Manual Section 6780.) The plan identifies resource management objectives and the planned means for achieving them.

herd management area: a herd area identified in an approved resource management plan where wild horses or burros will be maintained and managed.

herd management area plan (HMAP): an activity plan which addresses the management of wild horses or burros and their habitat on one or more herd management areas.

## H-1741-1 - FENCING

-L-

let-down fence panel: a section of fence that can easily be detached from its supporting posts for placement flat on the ground.

livestock, class of: age and/or sex groups of a kind of livestock.

livestock, kind of: species of domestic livestock, cattle, sheep, horses, burros, and goats.

-M-

maintenance: timely repair of an improvement or treatment project to keep it in usable condition for the purpose intended over its normal expected lifespan. Such repair is performed as needed and the cost is comparatively minor, or less than 50 percent of the cost of new construction to replace the facility. NOTE: This does not mean that when repair costs are greater than 50 percent of replacement costs, the complete removal and rebuilding of the project is always appropriate. The salvage and reuse of component parts, in good condition, may be appropriate.

management direction: established coordinated management direction developed during land use planning pursuant to the provision of FLPMA. It encompasses all resource management goals, objectives, constraints, exclusions, guidelines, etc., contained in or affected by land use planning decisions made by the authorized official for a particular Resource Area or other area encompassed by the land use or resource management plan.

migration routes: areas traversed by animal populations, commonly used year after year, in their habitual travels from one seasonal-use area to another.

modification: alteration of an improvement project, to meet specific resource needs. These needs may not have existed and thus were not considered during the original project design and construction. The needs may even have been considered previously, but available information and applicable management guidance did not provide a basis for adjustment of project design at that time.

movements, daily: routine movements to and from food, water, and cover within a 24-hour period.

movements, seasonal: movements of animals to and from summer, spring, fall, and winter use or habitat areas, sometimes over well-defined migration routes, but generally across broader habitat areas in response to changes in weather conditions.

H-1741-1 - FENCING

-R-

ranges: the regions or areas over which a particular species or kind of animals roam and feed. As used in here a range is essentially the same as a habitat management area or unit in that it applies to a particular group or herd of animals.

reconstruction: replacing or rebuilding an improvement facility or treatment (i.e., fence, spring development, cattleguard, and sometimes a vegetative manipulation) after the normal effects of climate, geologic action, design, use, or construction limitations leads to a determination that repairs will cost over 50 percent of a new facility or treatment. In most circumstances, reconstruction is the responsibility of the owner of the facility. However, if the reconstruction is the result of negligence or malice on the part of the party responsible for maintaining it, that party is responsible for reconstruction and may be assessed other penalties and/or costs. The salvage and reuse of component parts that are in good condition, may be appropriate in project reconstruction.

-S-

seasonal-use area: an identifiable use area which is normally used during only one or two seasons of the year, such as winter or summer, etc., and can be separated according to this use.

-W-

winter concentration areas: habitats providing favorable climatic, topographic, and vegetative conditions essential for wildlife survival during winter stress periods. Within these areas, animals often congregate in groups and move in response to storms, availability of food as determined by snow depth, and to seek shelter from prevailing winds offered by topographic relief.

## H-1741-1 - FENCING

BLM Fence Standards for Livestock and WildlifeKinds of Use Combinations

<u>Kinds of Livestock and Wild Burros</u>	<u>Predominant Big Game Wildlife Species</u>	<u>Number Wires</u>	<u>Max. Fence Height in Inches</u>	<u>Wire Spacing (From Ground Up, in Inches)</u>	<u>Wire Type</u>	<u>No. Stays Between Line Posts w/Spacing of 16.5' - 30'</u>
<u>STANDARD BUREAU FENCES:</u>						
Cattle	None	4	42	16, 6, 8, 12	Barbed.	1 to 4
Sheep	None	-	36	2, 24 (Woven) 2, 8	Woven, barbed.	
<u>STANDARD BUREAU MODIFICATIONS TO MEET MULTIPLE-USE NEEDS:</u>						
Cattle (only)	Antelope, Javelina, or Deer and Antelope.	3	38	16, 10, 12	Bottom strand smooth, others barbed.	One w/post spacing of 16.5' -- 1 or 2 w/post spacing of 30'.
Sheep (only)	Antelope, Javelina or Deer	4	32	12, 6, 6, 8 16.5' -- 1 or 2	Bottom strand smooth, others barbed.	One w/post spacing of 16.5' -- 1 to 3 w/post spacing of 30'.
Cattle and Sheep (Use only where sheep control is necessary.)	Antelope Javelina or Deer	4	38	15, 7, 8, 8	Bottom strand smooth, others barbed.	One w/post spacing of 16.5' -- 1 to 3 w/post spacing of 30'.
Cattle and Sheep (normal conditions)	Deer, Elk, Moose, or Antelope.	3	38	16, 10, 12	Bottom strand smooth, others barbed.	1 to 4
Cattle and sheep (Requires greater restriction of livestock movements.)	Deer, Elk, Moose, or Antelope.	4	40	16, 6, 6, 12	Barbed.	1 to 4
Cattle	Bighorn Sheep*	3	39	20, 15, 4	Barbed.	1 to 4
Cattle, Wild Burros	Bighorn Sheep* (Use around watering area)	-	42	18 to bottom rail; 34 and 42 to top of middle and top rails.	Rails 2"-3" diameter.	Line Post spacing 10 feet
Cattle, Wild Burros	Bighorn Sheep*	6	38	18, 4, 4, 4 4, 4	Bottom strand smooth, others barbed.	1 to 2

\*These fences also meet antelope, and deer standards.



**BLM WIRE SPACING STANDARDS**  
NOT TO SCALE

**Cattle Only**

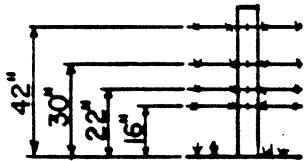

**Sheep Only**

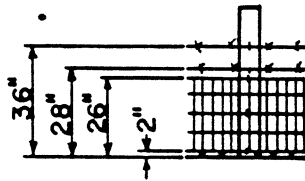

**Combination Of  
Cattle With Antelope,  
Javelina Or Deer And  
Antelope**

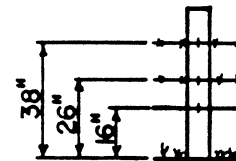

**Combination Of Sheep  
Antelope, Deer Or  
Javelina**

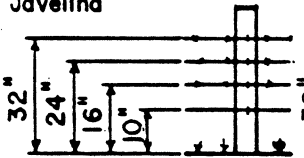

**Combination Of Cattle  
And Sheep With  
Antelope, Deer Or  
Javelina**

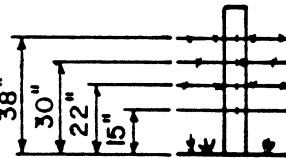

**Combination Of  
Cattle And Sheep  
(Under Normal  
Conditions) With  
Deer, Elk Or  
Moose**

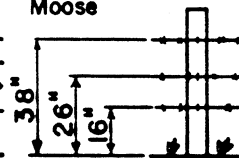

**Combination Of  
Cattle (Requiring  
Greater Restriction  
Of Livestock Movements)  
With Deer, Elk, Moose,  
Or Antelope**

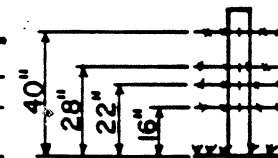

**Combination Of  
Cattle With Bighorn  
Sheep**

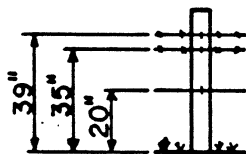

**For Bighorn Watering Areas;  
Combination Of Cattle With  
Burros And Bighorn  
Sheep**

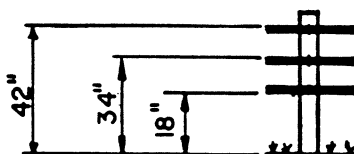

**Combination Of Cattle With  
Burros And Bighorn  
Sheep**



TYPICAL WIRE-MECHANICAL GATE CLOSERS  
NOT TO SCALE

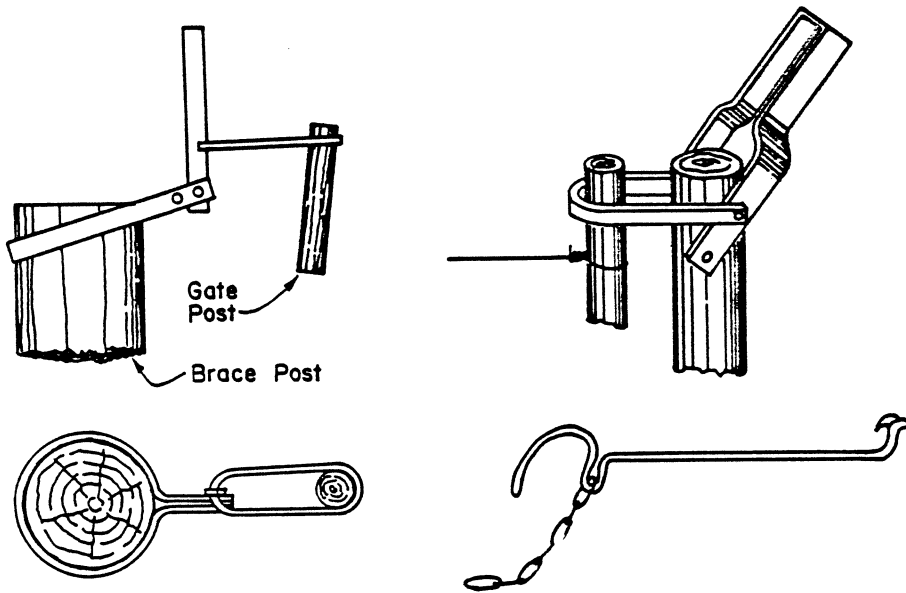

EXAMPLES OF STILES AND WALK THROUGH PASSES  
NOT TO SCALE

Preferred:

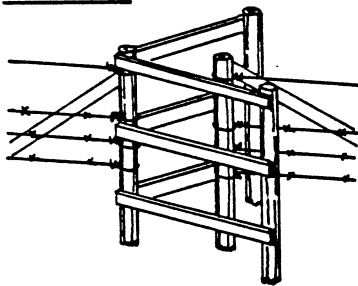

Pedestrian Walk Through

Optional:

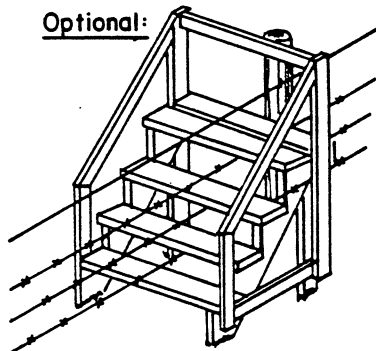

Step-Over Stile

Optional:

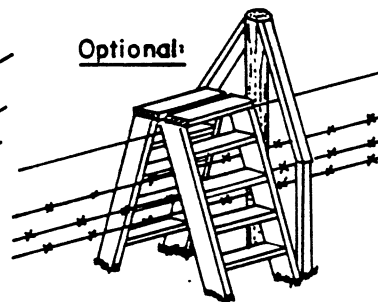

Step-Over Stile

Chapter 4

BARRIER HEIGHT INCREASE OF 42" FENCE ON CONTOUR  
OF DIFFERENT PERCENT SLOPES

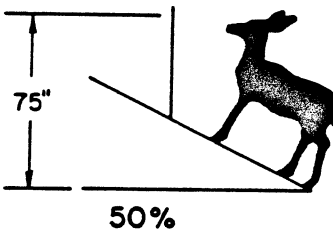
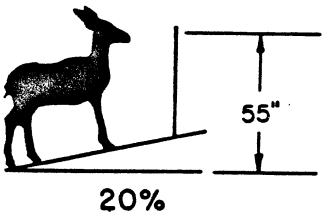
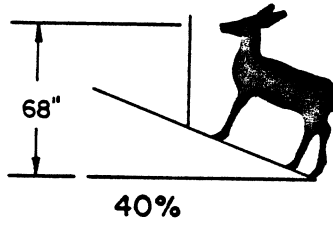
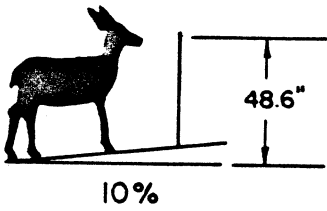
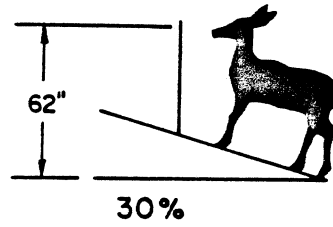
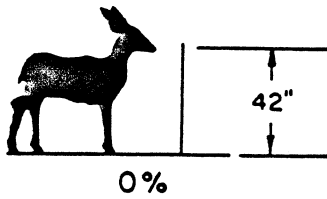

TYPICAL ANTELOPE PASS  
NOT TO SCALE

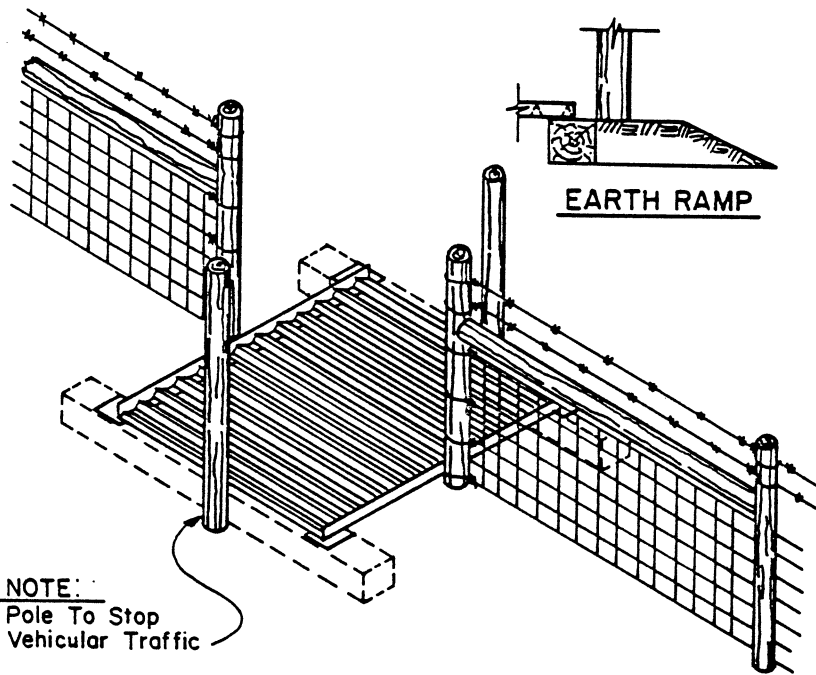

NOTE:  
Pole To Stop  
Vehicular Traffic

ISOMETRIC VIEW

EXAMPLES OF  
ADJUSTABLE THREE-STRAND 38" HIGH FENCE FOR ANTELOPE  
NOT TO SCALE

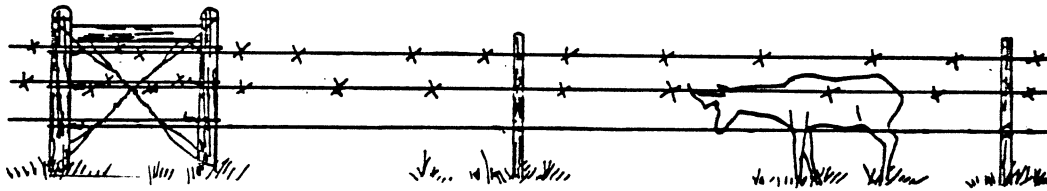

STANDARD CONFIGURATION

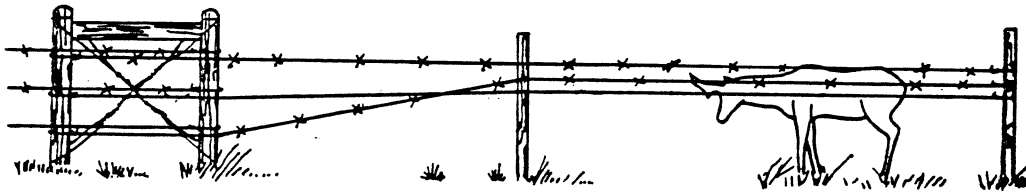

MODIFICATION FACILITATING MOVEMENT UNDER MOST CONDITIONS

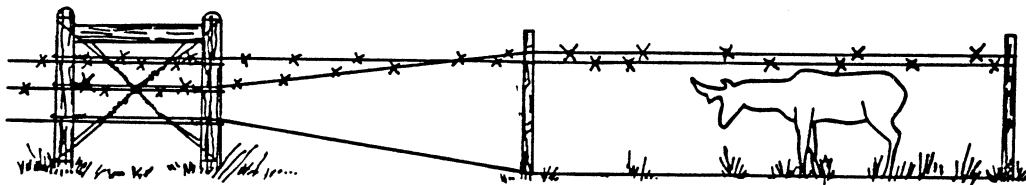

ADJUSTMENT ALLOWING ALMOST TOTAL FREEDOM OF MOVEMENT

EXAMPLES OF  
ADJUSTABLE FOUR-STRAND FENCE  
FOR DEER  
NOT TO SCALE

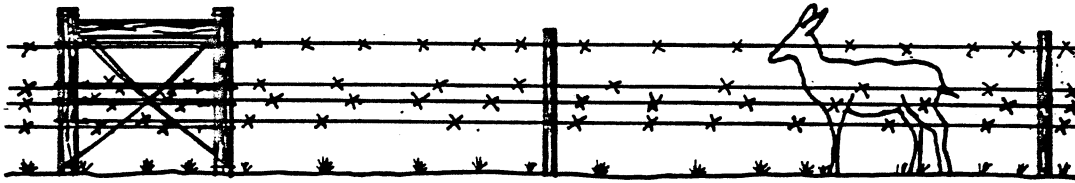

STANDARD CONFIGURATION

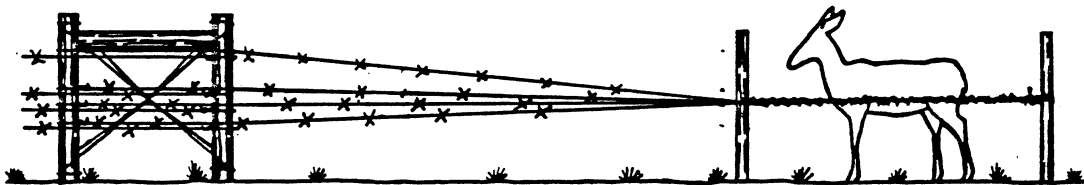

MODIFICATION ALLOWING NEARLY FREE MOVEMENT

**EXAMPLES OF**  
**FASTENING MECHANISMS FOR ADJUSTABLE WIRE FENCE**

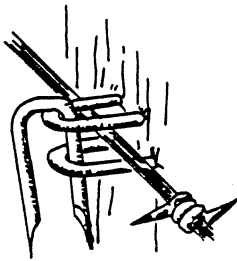

**Staple Lock** - Simple And Effective On Wood Posts.  
Holds Wire Tight If Standard Fence Staples Are Used.

**Hook** - Made From Large Square-End Staple.  
Quite adequate For Bottom Hook But Difficult  
To Drive Into Untreated Portion Of Post. Use  
In Conjunction With Staple Lock Or Metal Clip.

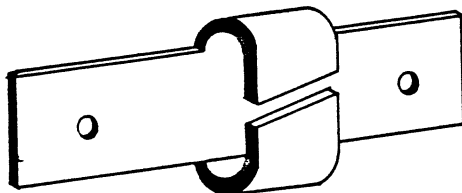
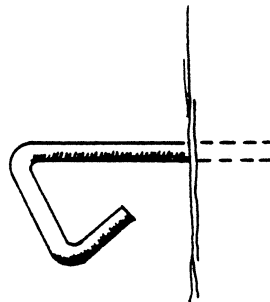

**Metal Clip** - Excellent On Either  
Wood Or Steel Posts. Easy To  
Install, No Maintenance And  
Allows Fastest Wire Adjustment.  
Existing Fences Easy To Modify  
With This Clip.

EXAMPLE OF  
LET-DOWN FENCE  
NOT TO SCALE

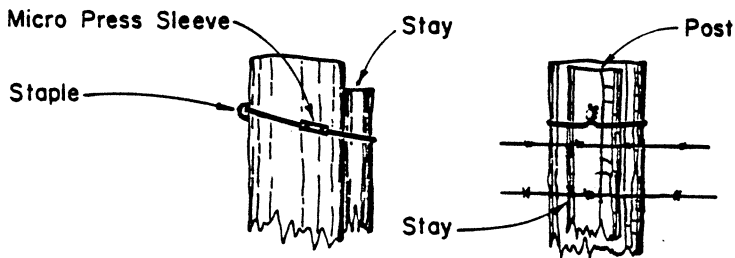

DETAIL OF FASTENER

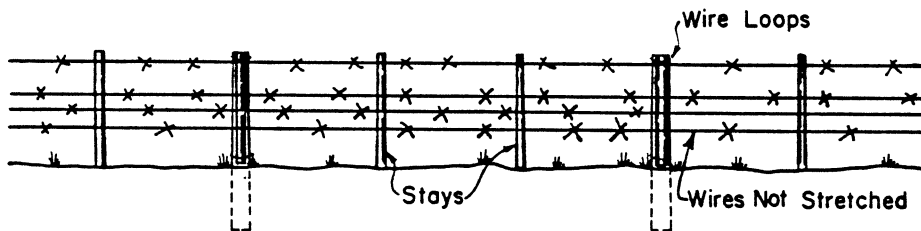

NOTE: Steel Posts May Be Used



H-1741-1 - FENCING

Chapter 4

FENCE STAYS  
NOT TO SCALE

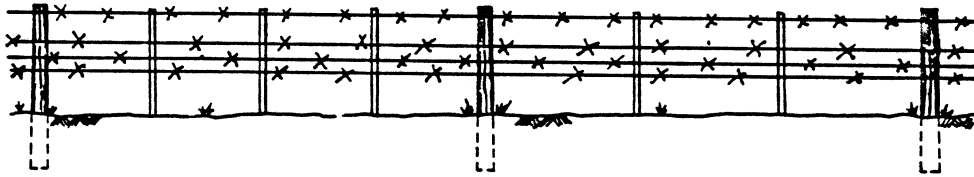

SECTION OF LINE FENCE  
4-Wires With 2 Or 3 Stays

NOTE:

Same Spacing And Post Length Applies To Steel Fence Posts.  
Two or Three Equi-Distant Stays Are Good Construction.

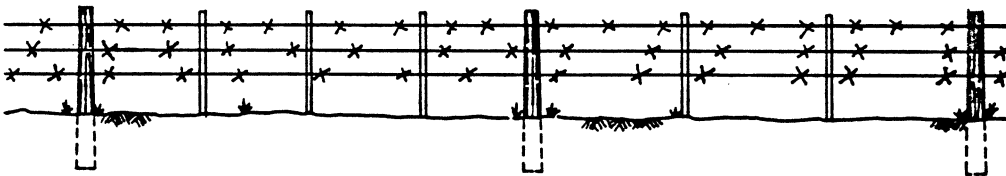

SECTION OF LINE FENCE  
3-Wires With 2 or 3 Stays

H-1741-1 - FENCING

Chapter 4

TYPICAL POST & POLE FENCE  
NOT TO SCALE

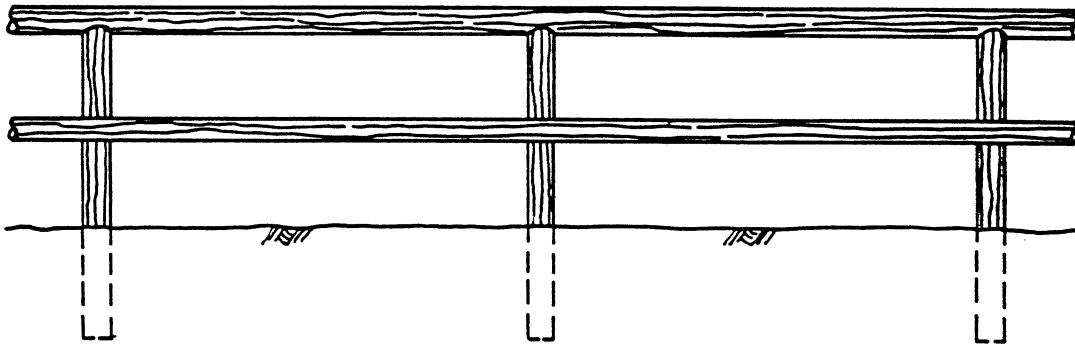

TYPICAL BUCK & POLE FENCE  
NOT TO SCALE

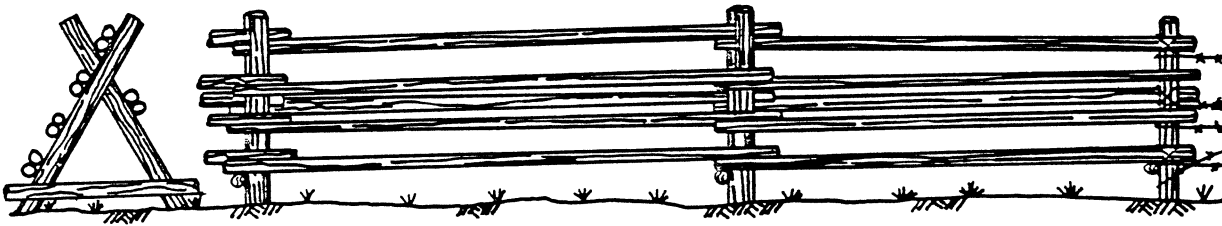

TYPICAL POST, POLE & WIRE FENCE  
FOR ROCKY MOUNTAIN BIGHORN USE AREAS

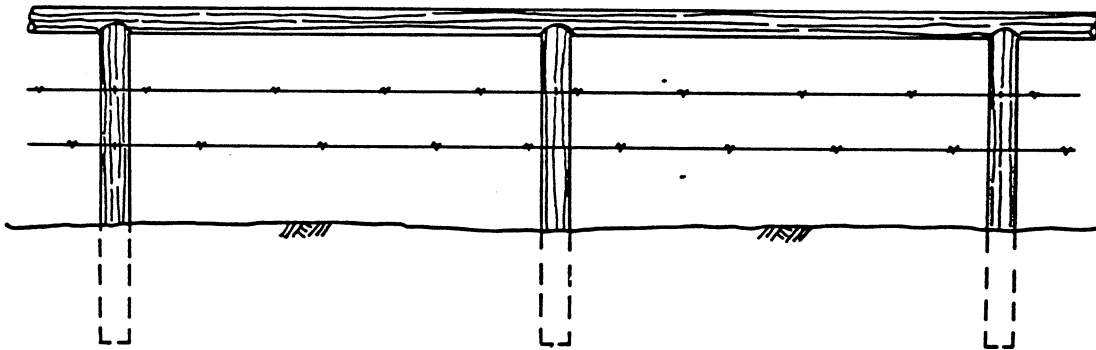

NOT TO SCALE

EXAMPLE OF SMOOTH WIRE FENCE  
NOT TO SCALE

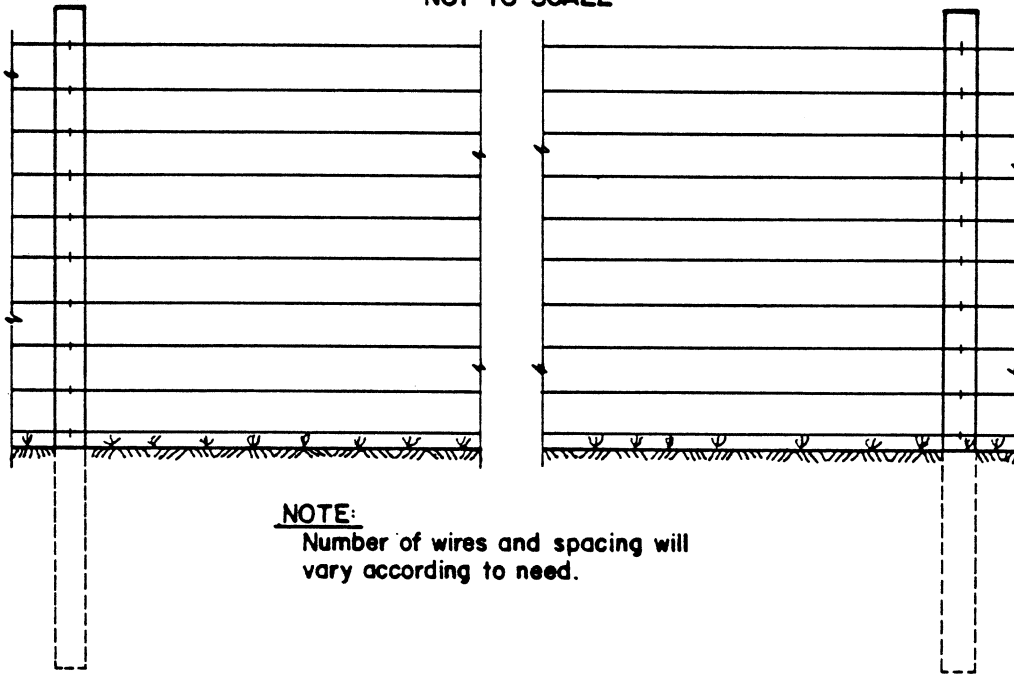

NOTE:  
Number of wires and spacing will vary according to need.

TYPICAL  
SUSPENSION FENCE  
NOT TO SCALE

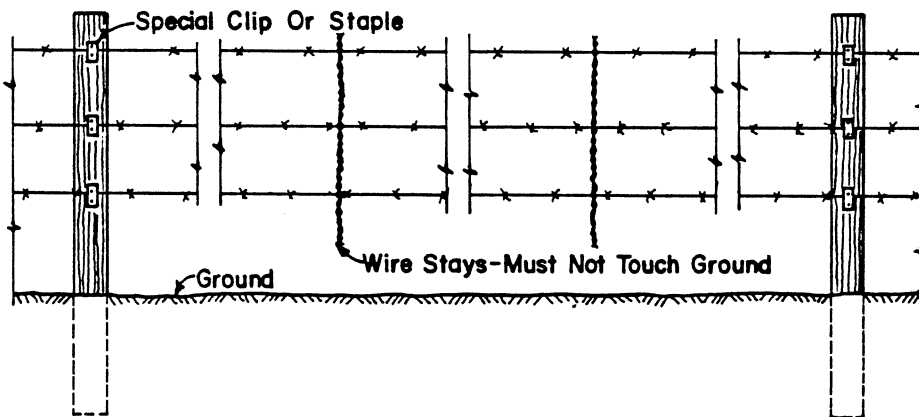

ELEVATION

H1741-1 - FENCING

Chapter 4

EXAMPLES OF ELECTRIC FENCES  
NOT TO SCALE

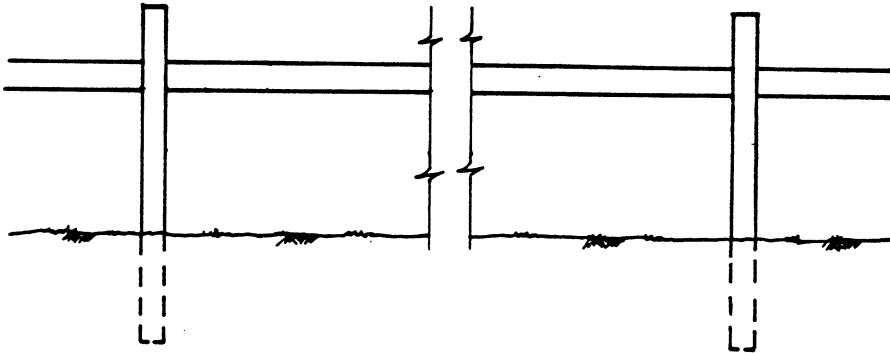

TWO WIRE FENCE

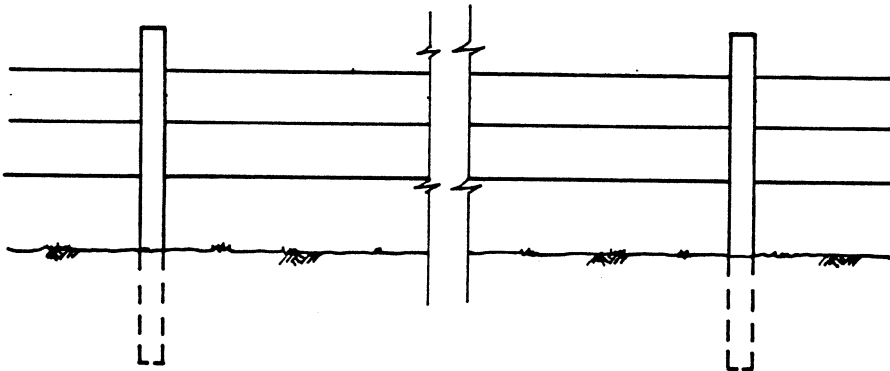

THREE WIRE FENCE

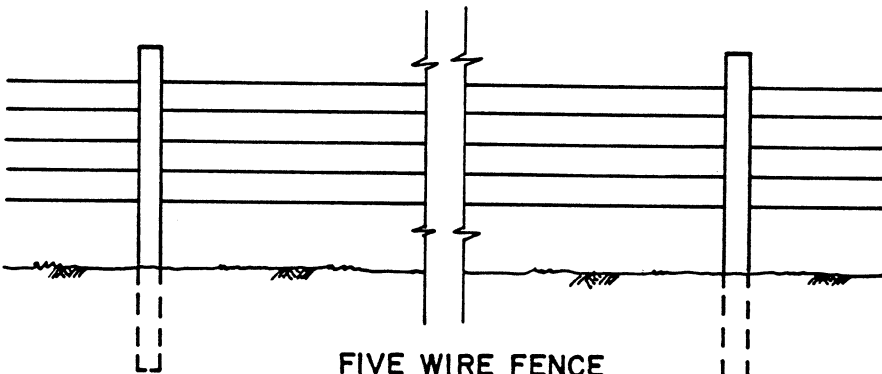

FIVE WIRE FENCE  
For  
Special Application

EXAMPLES OF STRAIN INSULATOR  
FOR ADJUSTABLE WIRE FENCES  
NOT TO SCALE

Smooth Wire To Let Out And  
Take Up Slack

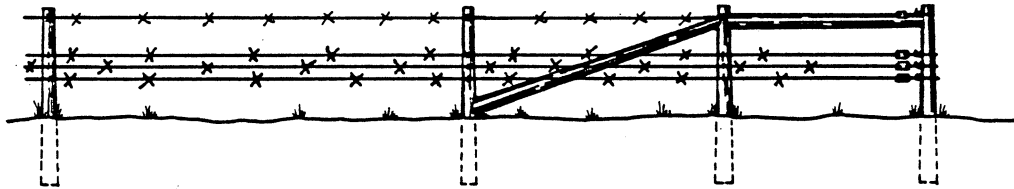

NOTE: Steel Posts May Be Used.

Chapter 4

STUDY ENCLOSURE

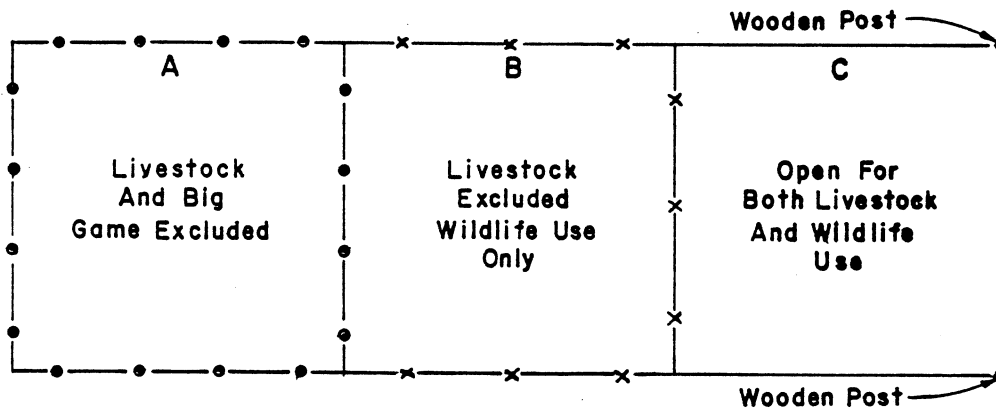

Total Enclosure Size Should Be 5 To 100 Acres. Each Paddock Should Contain An Equal Portion Of The Habitat.

Chapter 4

**EXAMPLES OF BIG GAME PROOF FENCING**

**8'-0" HIGH WOVEN WIRE FENCE**  
NOT TO SCALE

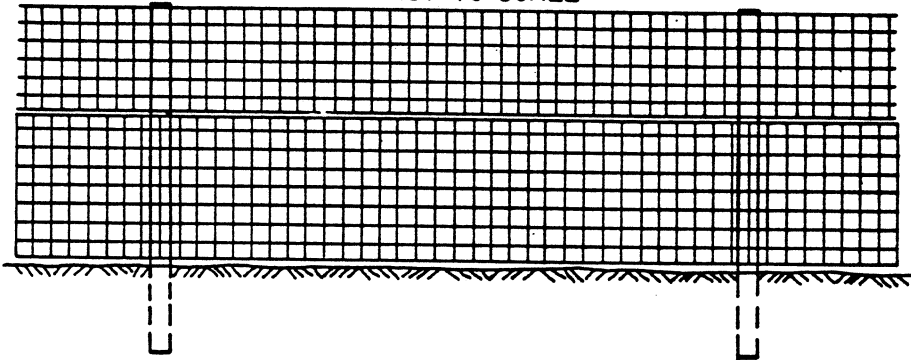

**8'-0" HIGH WOVEN/SMOOTH WIRE FENCE**  
NOT TO SCALE

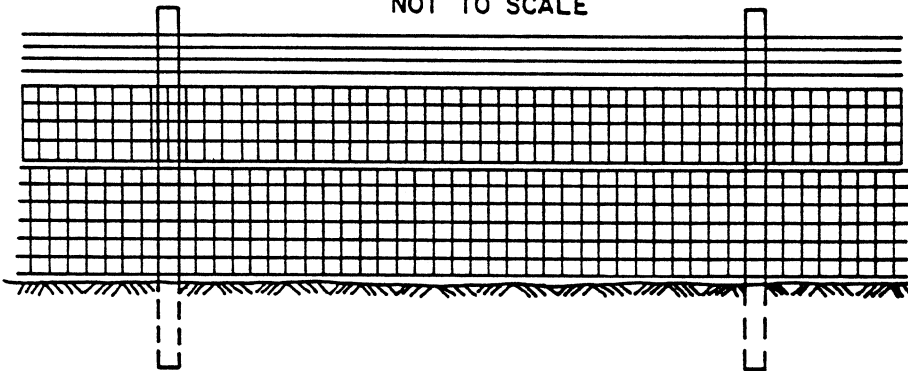

**OREGON OUTRIGGER FENCE**  
NOT TO SCALE

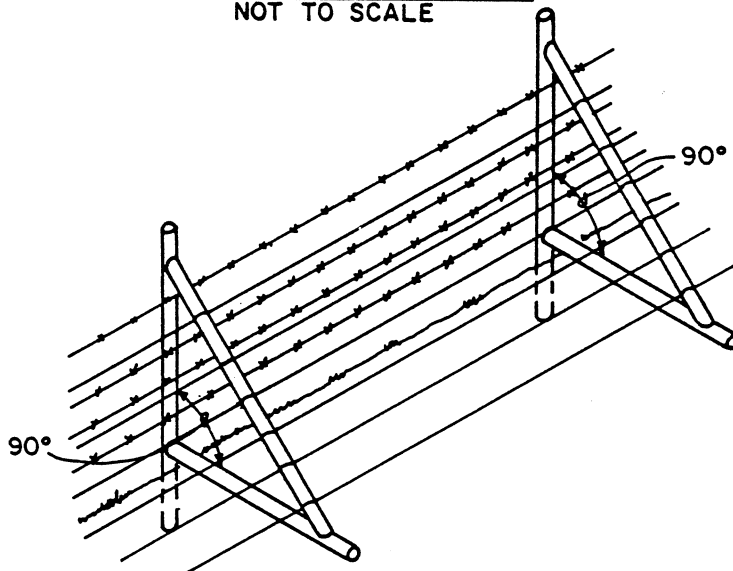

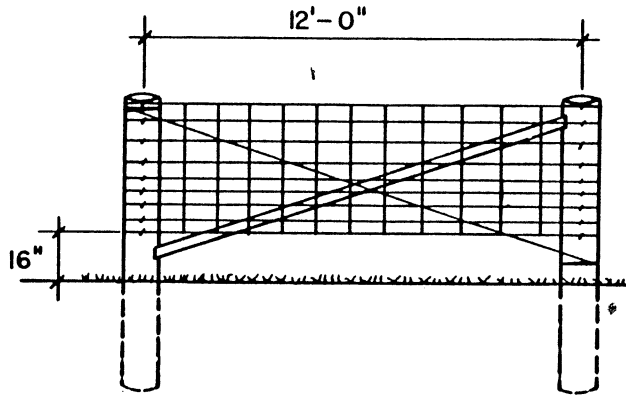

WOVEN WIRE (47 IN., 11-GA.)

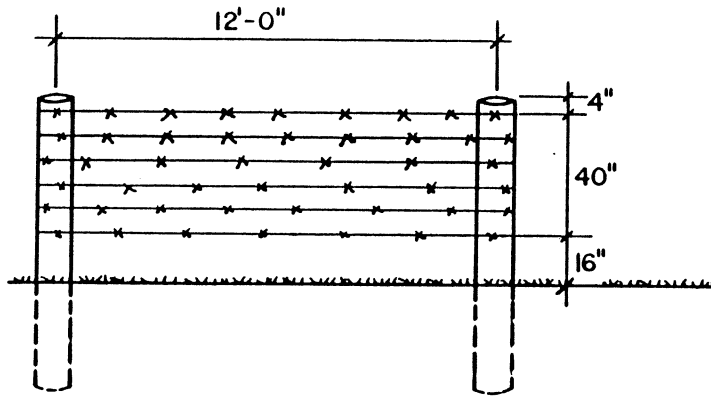

BARBED WIRE

BISON FENCE PANELS

NOT TO SCALE

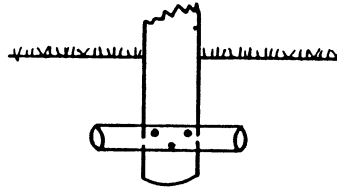

ANCHORING METHOD FOR  
DEEP GULLY CROSSINGS.



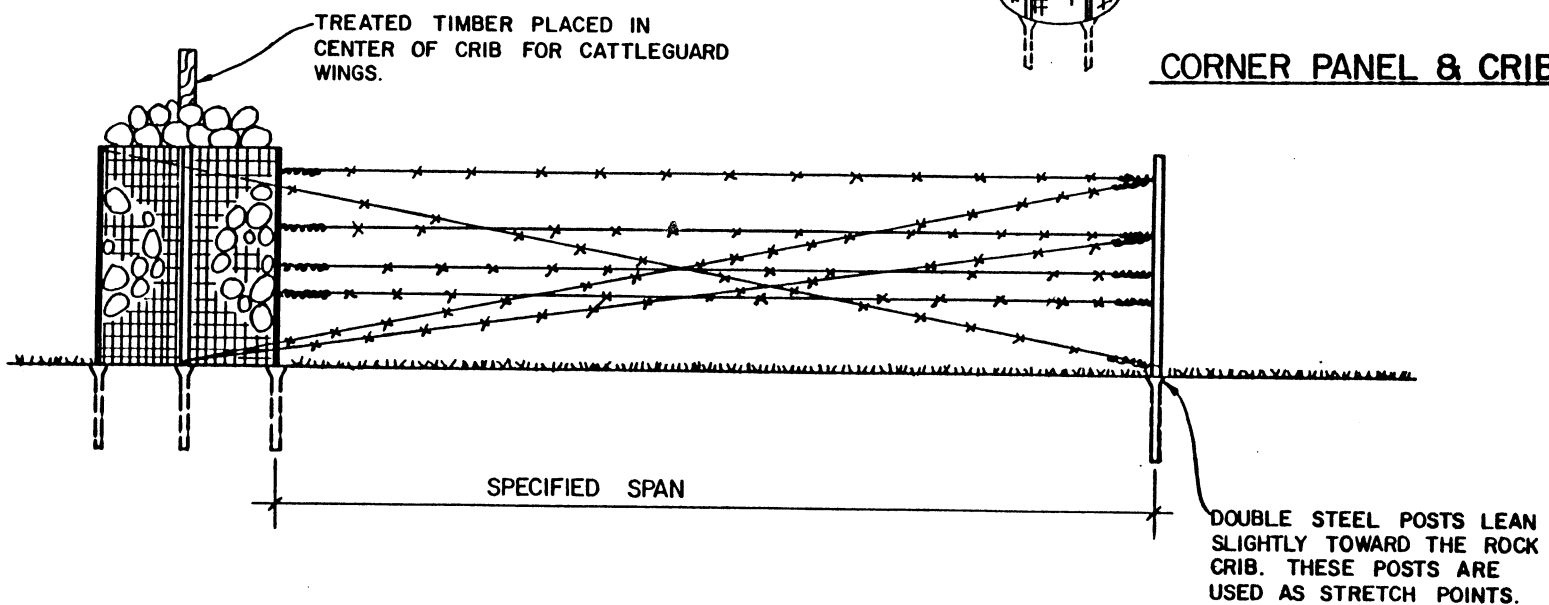
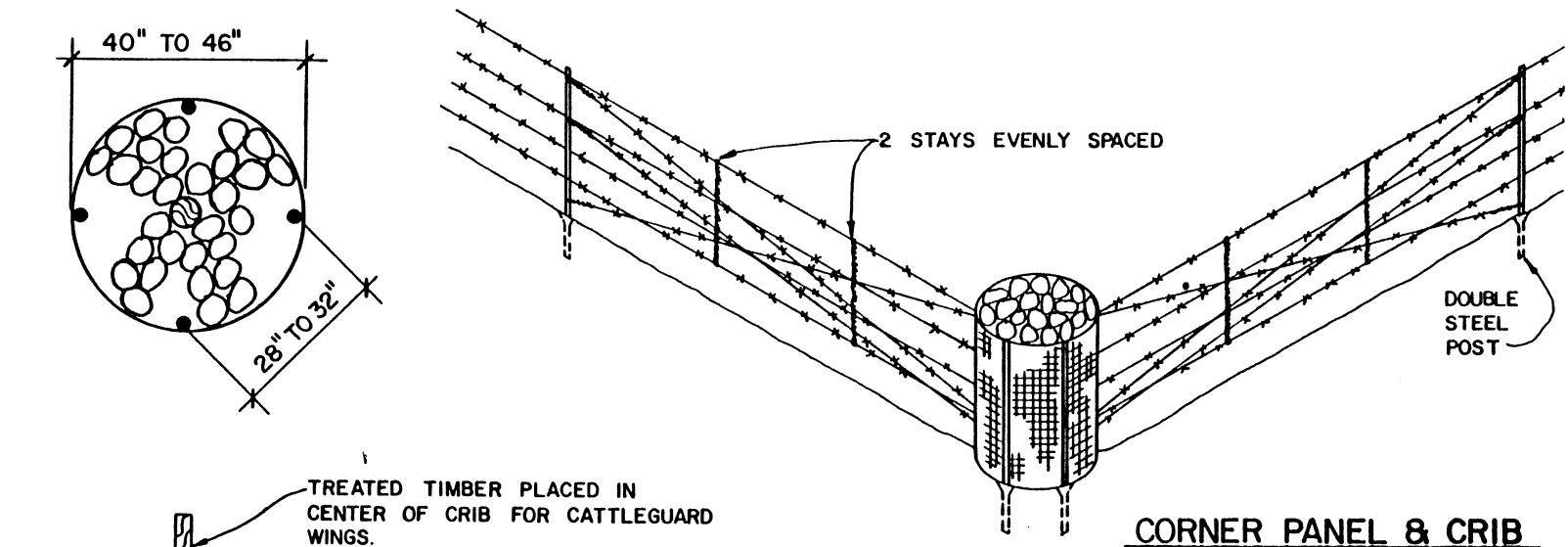

ROCK CRIB & STRESS PANEL  
NOT TO SCALE

Chapter 4

H-1741-1 - FENCING